

---

# APBA

AMERICAN POWER BOAT ASSOCIATION

## ***2017 PRO Technical Manual***



*All photos © copyright by Teri Ziemer. All rights reserved.*

### ***Professional Racing Outboard Category American Power Boat Association***

*17640 East Nine Mile Road  
PO Box 377  
Eastpointe, Michigan 48021-0377*

*Phone: (586) 773-9700  
Fax: (586) 773-9490  
Email: [apbahq@apba-racing.com](mailto:apbahq@apba-racing.com)  
Web: [www.apba-racing.com](http://www.apba-racing.com)*

© Copyright 1988 – 2017, Professional Racing Outboard (PRO) Category of the American Power Boat Association.  
All rights reserved. This manual may be copied, in whole or in part, including photos, by APBA members for their personal use only, provided no changes are made to the manual's format or content.  
Document Number: PRO-2017-3, Revision Date: 05/02/17

---

## Table of Contents

PRO Technical Manual.....	3
PRO Category Racing .....	4
Boats .....	4
Hydros .....	4
Runabouts .....	4
Motors .....	5
Getting Started .....	5
Suppliers.....	6
Race Boats.....	6
Motors, Parts, Repairs.....	6
Propellers .....	7
Hardware .....	7
Fuel, Lubricants.....	8
Safety Equipment .....	8
Colonel Green Round Hill Trophy Winners .....	9
PRO Category's APBA Hall of Champions Inductees .....	10
George H. Townsend Medal.....	11
The Gary Wyhoski PRO Officials Award .....	12
PRO Category's Organization .....	12
2017 PRO Commission.....	14
2017 PRO Committees .....	15
PRO Championship Referees, Scorers, and Inspectors.....	16
PRO Classes .....	18
PRO Class Participation .....	19
PRO Safety Rules.....	20
Safety Summary.....	20
Safety Summary for Reinforced Cockpits .....	20
Technical Class Rules .....	23
General Technical Summary.....	23
Legal Motors.....	23
4-Stroke Maximum Displacement Table .....	24
Driver's Age .....	25
Minimum Runabout Lengths .....	25
Runabout Restrictions .....	26
Hydroplane Restrictions .....	26
Displacement-based Classes .....	27
Additional Class Restrictions.....	27
Stock and Mod Motors (Cross-overs and Step-downs) .....	28
Motor-based and Restricted Classes .....	29
K PRO Hydro.....	29
OSY400.....	36
C Service Runabout & Hydro .....	47
C Racing Runabout & Hydro.....	48
C Service and C Racing Class Boat Rules .....	50
C Service and C Racing Class Motor Rules .....	51
Conversion Tables.....	54
Fraction / Decimal Equivalents.....	54
Metric Conversion .....	54

## PRO Technical Manual

The purpose of this manual is to bring together in one document information needed to race within the PRO Category of the American Power Boat Association. This manual is intended to supply accurate and complete information that can be used as reference for a range of purposes from the beginner to the inspector. This manual is a compilation of information from the American Power Boat Association Rule Book, motor manufacturers' specifications, PRO Commission decisions, and other sources. **Should any technical differences exist between this manual and the source materials, the source materials should prevail.**

Comments and updates concerning this manual should be directed to the current PRO Category Chairman. Revisions will be made as required. The latest version may be downloaded and printed from the PRO web site. It is available in Adobe PDF format. Go to [www.apba.org](http://www.apba.org). Printed copies may also be obtained from the APBA office or the PRO Category Chairman.

Kristi Ellison  
PRO Category Chairman  
E918 Cherneyville Road  
Luxemburg, WI 54217  
Email: [parroth222@aol.com](mailto:parroth222@aol.com)

American Power Boat Association  
17640 East Nine Mile Road  
PO Box 377  
Eastpointe, Michigan 48021-0377  
Phone: 586-773-9700  
Fax: 586-773-6490



***The cover photo and all photos in the PRO Technical Manual are by Teri Ziemer of Vacaville, CA. All photos were taken at the 2007 PRO National Championships in DePue, IL. Thank you very much, Teri.***

## PRO Category Racing

The Professional Racing Outboard (PRO) Category of the American Power Boat Association (APBA) offers a variety of outboard racing classes ranging from moderate speed to very fast, from old tech to high tech, from low investment to substantial investment. No other category of outboard racing offers such diversity. The PRO Category is also the oldest of the outboard categories, having its roots in the 1920's.

Even with such diversity, however, the basics are the same. Put together a stable boat, a strong motor, the correct propeller, you in the cockpit, a little skill and a little luck, and you'll be able to compete at the top of whatever class you choose to run. The diversity also encourages family racing, with a class for every taste.

The classes taken together can be a bit confusing. Each class has its own class technical rules. How do you choose the best class or classes for you and your pocketbook? If we break the rules down to the basics, the choices will be easier. First we'll cover boats, then motors, then the rules.

### Boats

Boats in the PRO Category are roughly 9 to 14 feet in length and weigh perhaps 100 to 250 pounds. Most are made of wood. Mahogany decking and spruce framing are popular. Carbon fiber, honeycomb, and other high tech materials are also used. Most offer a cockpit without a seat. The driver crouches and kneels in the cockpit. Some are driven in a lay-down position and some have the driver seated. Typically the left hand works the spring-loaded throttle and the right hand handles the steering wheel. Both hands also attempt to stabilize the driver in the cockpit. Generally the boats are of two distinct designs referred to as Hydros and Runabouts.

### Hydros

Hydros typically trap air beneath them and thus ride on a cushion of air. Most common is the so-called three-point design where the boat contacts the water's surface on two sponsons or outriggers forward and the bottom of the boat near the stern. Often the propeller is the only point of contact between the boat and the water. The design of hydros in the PRO Category is generally unrestricted. The hydro classes, therefore, offer a challenge for those who wish to experiment in boat design and construction.

### Runabouts

Runabouts have certain restrictions in design defined by the PRO rules. The various classes have minimum lengths defined for the Runabout hull. While there is great variety in runabout design, generally they have a flat riding surface, are tapered back from a point, and are not designed to channel air under the hull. Runabouts are typically slightly slower than hydros when utilizing a similar motor. The runabout design sometimes allows the boat to be driven partially on the boat's side when rounding a buoy.

## Motors

Motors in the PRO Category are generally two-stroke, although 4-stroke motors are permitted, and are divided into classes based upon the amount of piston displacement. Each class has an allowable maximum of piston displacement. Most classes measure this displacement in cubic centimeters (cc's) but others are measured in cubic inches. Many classes are generally unrestricted while others have very specific restrictions on motors and modifications to motors. The motors range from 125cc to 1133cc displacement.

While the class names of some motors are designated by the maximum displacement allowed, other class names use a single letter code designation to indicate the displacement of the motor. The single letter code designations currently used are "K", and "C". These refer to "Kids" and 30 cubic inches respectively.

## Getting Started

In order to race, you need a boat and a motor that qualify within the rules of one of the PRO classes and you must meet the age requirements for the class. You will also need to be a current member of both the American Power Boat Association (APBA) and a local club that is a member of APBA. The APBA membership provides you with insurance, boat numbers, notification of races, tracking of points, and many other services.

APBA membership applications are available from the American Power Boat Association at PO Box 377, East Detroit, Michigan 48021, (586) 773-9700. You can also join APBA online at [www.apba.org](http://www.apba.org). When you apply, be sure to indicate that you wish to join the PRO Category. When you become a member of APBA, you will receive a membership card, boat numbers, a rule book, a reference book, a monthly magazine, boat decals, and notification of races in your area.

If you can, try to attend a local race or two before investing in your equipment. Not all classes are run actively in all parts of the country, so try to join a class that your local club actively schedules. You can't have a race without competition.

***Good luck. Race safe. Have fun.***



## Suppliers

The following is a listing of suppliers of PRO racing components. APBA's PRO Category makes no representation that this list is complete. Inclusion on this list does not imply any endorsement by APBA or the PRO Category of any product or service. Updates to this listing should be forwarded to the PRO Category Chairman for inclusion in the next edition.

### Race Boats

Broccoli Brand Runabouts, Box 87, Rosemont, NJ 08556, Phone: 609-297-2840	Boats, kits
Carl Staron, Staron Boats, 587 Lake Apthorpe Dr., Lake Placid, FL 33852, Phone: 863-699-9701	Boats, motor parts
Darrell Sorensen, Sorensen Woodcraft, 13307 Avenue 22 ½, Chowchilla, CA 93610, Tech line: 209-665-2690, Orders: 1-800-891-1808, Fax: 209-665-2490	Race boats, kits, plans, lumber, Yamato motors, hardware
Ernie Dawe, Dawe Craft Boats/Hardware, 82-138 Tahquitz, Indio, CA 92201, Phone: 760-347-3287	Race boats, hardware
Fralick Boats, Web: <a href="http://www.fralickboats.com">www.fralickboats.com</a> , Phone: 905-838-3448	Boats, plans, oil, paints, lumber, hardware
Gary Pugh, Pugh Race Boats, 3717 Schaad Road, Knoxville, TN 37921, Phone: 423-693-8840	Race boats
Jim Apel, Apel Custom Boats, Email: <a href="mailto:jimapel@cfl.rr.com">jimapel@cfl.rr.com</a> , Phone: 352-874-1099	Race boats
Jon DuVernet Steen, JDS Extreme Racing, 5039 38 <sup>th</sup> SW, #3, Seattle, WA 98126, Phone: 206-935-7878	Race boats, repairs, paint
Marc Johnson, MJR – Marc Johnson Racing, Email: <a href="mailto:mjrboatplans@bellsouth.net">mjrboatplans@bellsouth.net</a>	Race boat plans
Mike Krier, Krier Boats, RR 1, Box 15, Ollie, IA 52576, Phone: 515-622-1009	Race boats
Ralph De Silva, De Silva Boats, 56 Pierce Road, Hiram, Georgia 30141, Phone: 770-943-9494	Race boats, hardware

### Motors, Parts, Repairs

Dave Jones / Fred Suhy, Gold Mine Motor Service, Phone: 203-888-2999 / 203-925-0888	Yamato motor service
Dudley Malone, Central Marine Company, PO Box 32572, Oklahoma City, OK 73123, Phone: 405-721-2755	Motor service, parts, hardware
Ed Thirlby, Thirlby Automotive Racing, Inc., 145 Roman Drive, Traverse City, MI 49684, Phone: 616-943-4524	Racing motor building, parts, repair
Karl Williams, Karl Williams, Inc., 2920 South MacArthur Blvd., Springfield, Illinois 62704, Phone: 217-528-6873	C Service and C Racing motors, parts, hardware
Mike Schmidt, 28 Cherry Lane, Durham, CT 06422. Phone: 860-349-9310, Email: <a href="mailto:teammsr@comcast.net">teammsr@comcast.net</a>	Motor repair, welding

R. C. Hawie, Hawie Racengineering, PO Box 61, Lake Hamilton, FL 33851, Phone: 941-223-3860	Racing motor building, parts, repair
Rex Hall, 5495 W. Gale Road, Smithville, MO 64089-8453, Phone: 816-532-4598, Email: <a href="mailto:RexfordHall@aol.com">RexfordHall@aol.com</a>	Rossi sales and repair
Ric Montoya, RPM Marine, 2541 7 <sup>th</sup> Avenue West, Seattle, WA 98119, Phone/fax: 206-283-4773, Orders: 1-800-YAMATO1	Yamato motors, parts, hardware, lumber, kits
Robert Goller, Eastern Auto & Boat Specialties, 52 West Street, West Hatfield, MA 01088, Phone: 413-247-5781	Yamato motor building, parts
Sid Bass, N.W. Lower Unit Company, 2622 Rockpoint Road, Bremerton, WA 98312, Phone: 360-373-3839	Racing lower units, towerhousings, Tohatsu motors
Steve Greaves, Portage Bay Systems, 3110 Portage Bay Place East, Seattle, WA 98102, Phone: 206-371-0486 <a href="http://www.portagebaysystems.com/marine">www.portagebaysystems.com/marine</a>	Arens PRO Racing Motors, Hot Rod & Sidewinder Racing Outboards, C Racing gears
Steve Litzell, Outboard Marine Service, 1155 Wedgefield Drive South, Marietta, GA 30064, Phone: 770-428-0568	VRP & Konny sales and repair

## Propellers

Craig Dewald, Dewald Racing Propellers, 1050 Rick Road, Reading, PA 19605, Phone: 610-926-2964	Propellers
Glen Hopkins, Hopkins Propeller Service, 70415 Charlie Street, Covington, LA 70433, Phone: 504-892-3868	Propellers
Harry Pinner, Props by Pinner, 17030 131 <sup>st</sup> Terrace North, Jupiter, FL 33478, Phone: 561-743-9238	Propellers, Yamato motors

## Hardware

Alan Brown, Brown Tool & Machine Co., PO Box 142, Rosemont, NJ 08556, Phone: 609-397-1751	Race boat hardware
Digitron, 8102 North Freya, Spokane, WA 99207, Phone: 509-467-3128	Tachometers, gauges
Lee Tietze, 1004 NE 4 <sup>th</sup> . Canby, OR, Phone: 503-263-2508, Fax: 503-263-7924	Custom machined components
Steve Greaves, Portage Bay Systems, Inc., 3110 Portage Bay Place East, Seattle, WA 98102, Phone: 206-371-0486, Fax: 206-329-4952, Email: <a href="mailto:sgreaves@portagebaysystems.com">sgreaves@portagebaysystems.com</a> , Web: <a href="http://www.portagebaysystems.com/marine">www.portagebaysystems.com/marine</a>	CMP/Keller race boat hardware, speedometers
Tom Cronk, TEC Craft, 3528 Lori Lane N., Lakeland, FL 33801, Phone: 865-665-5449, Email: <a href="mailto:tcronk@tampabay.rr.com">tcronk@tampabay.rr.com</a>	Race boat hardware

## Fuel, Lubricants

Blendzall, 310 South First Street, Martins Ferry, OH 43935, Phone: 614-633-1333	Lubricants
Klotz Special Formula Products, Inc., 7424 Freedom Way, Fort Wayne, IN 46818, Phone: 800-242-0489	Lubricants
Rick Fales, Power Mist Racing Fuels, 67 Stickles Pond Road, Newton, NJ 07860, Phone: 201-363-1061	Racing fuels, lubricants

## Safety Equipment

Lifeline, 1601 Kofa Avenue, Parker, AZ 85344, Phone: 928-669-9241, Fax: 928-669-8895	Lifejackets, Kevlar driving suits, helmets, uniforms
Patrick Gleason, Gleason Racing, Phone: 206-794-4597, Email: <a href="mailto:patrickgl@msn.com">patrickgl@msn.com</a>	Security safety products
Security Race Products, 1105 12 <sup>th</sup> Ave. NW, Suite A5, Issaquah, WA 98027, Phone: 425-557-6508	Lifejackets, Kevlar driving suits, helmets
Steve Greaves, Portage Bay Systems, 3110 Portage Bay Place East, Seattle, WA 98102, Phone: 206-371-0486 <a href="http://www.portagebaysystems.com/marine">www.portagebaysystems.com/marine</a>	Lifeline jackets, cut-suits; Bell helmets
Simpson, 2415 Amster Street, Torrance, CA 90505, Phone: 800-717-2246	Helmets, safety harnesses





## Colonel Green Round Hill Trophy Winners

The Colonel Green Round Hill Trophy is presented annually by APBA and the PRO Category to the driver with the most points during the season in the Professional Racing Outboard Category. The trophy has been presented since 1933 and is the most prestigious award presented by the PRO Category.

The trophy is 44" high, 19" diameter, and contains 286.20 troy ounces of sterling silver. The trophy is inscribed with the following: *"Round Hill Trophy presented to New Bedford Yacht Club by Colonel E. H. R. Green for Outboard Motor Boat Racing under auspices of American Power Boat Association 1930"*. The past winners of the Colonel Green Round Hill trophy are:

1933	Samuel Crooks, Rutgers	1988	Joseph E. Garrick, Sr., Ocoee, FL
1934	Joel Thorne, Rutgers	1989	Steve Greaves, Seattle, WA
1935	Samuel Crooks, Rutgers	1990	Daniel W. Kirts, Bristol, IN
1936	Ward Angilley, Marysville, CA	1991	Steve Greaves, Seattle, WA
1937	Douglas C. Fonda, New York, NY	1992	Daniel W. Kirts, Bristol, IN
1938	Clinton R. Ferguson, Waban, MA	1993	Steve Greaves, Seattle, WA
1939	Clinton R. Ferguson, Waban, MA	1994	David Hooten, Bartow, FL
1940	Frank J. Desmond, Short Hills, NJ	1995	Chris Hellsten, Orlando, FL
1941	Frank J. Desmond, Short Hills, NJ	1996	Chris Hellsten, Orlando, FL
1946	Frank J. Desmond, Bernardsville, NJ	1997	Pete Hellsten, Edgewater, FL
1947	John L. Schoolcraft, Schenectady, NY	1998	Steve Greaves, Seattle, WA
1948	Harold W. Peters, Los Gatos, CA	1999	Chris Hellsten, Orlando, FL
1949	Donald H. Whitfield, Montclair, NJ	2000	Steve Greaves, Seattle, WA
1950	Donald Lowry, Sacramento, CA	2001	Jamie Nilsen, Auburn, WA
1951	W. B. Barron, Jr., Memphis, TN	2002	Chris Hellsten, Orlando, FL
1952	William L. Tenney, Dayton, OH	2003	J. Michael Kelly, Puyallup, WA
1953	Thomas Ingalls, Los Angeles, CA	2004	Jamie Nilsen, Tacoma, WA
1954	Chuck Parsons, Lodi, CA	2005	Tony Lombardo, Concord, CA
1955	Ward Angilley, Daly City, CA	2006	Tony Lombardo, Concord, CA
1956	Chuck Parsons, Lodi, CA	2007	Brandon Thirlby, Traverse City, MI
1957	Bud Wiget, Lakeland, FL	2008	Brandon Thirlby, Traverse City, MI
1958	Rockey Stone, Willamina, OR	2009	Michael W. Schmidt, Durham, CT
1959	Rockey Stone, Willamina, OR	2010	Jim Nilsen, Edgewood, WA
1960	Harry Bartolomei, San Leandro, CA	2011	Jim Nilsen, Edgewood, WA
1961	Bud Wiget, Lakeland, FL	2012	Amy Nydahl, Bristol, WI
1962	Bud Wiget, Lakeland, FL	2013	Jay Walls, Jr., Danville, IN
1963	Fred Hauenstein, Jr., Kingsburg, CA	2014	Jay Walls, Jr., Danville, IN
1964	John Riner Woods, St. Louis, MO	2015	Jim Nilsen, Edgewood, WA
1965	Jack Stanford, Englewood, FL	2016	Justin Gibson, Washington, IL
1966	Jack Stanford, Englewood, FL		
1967	Bryan McDougall, Brigham City, UT		
1968	Jane E. Smith, Ridley Park, PA		
1969	Bob Vieira, Oakland, CA		
1970	Ted May, Fountain Valley, CA		
1971	Fred Hauenstein, Jr., San Jose, CA		
1972	Tommy Hooten, Wauchula, FL		
1973	Tommy Hooten, Wauchula, FL		
1974	Henry P. Shakeshaft, III, Bedford, VA		
1975	Malcom Harden, Portsmouth, VA		
1976	Don Wood, Fairmont, WV		
1977	Bill Troyer, Lakeland, FL		
1978	Joseph S. Tomaini, Long Branch, NJ		
1979	Richard Krier, Indianola, IA		
1980	Henry P. Shakeshaft, III, Bedford, VA		
1981	James D. MacKay, Modesto, CA		
1982	Hoz Compton, Lake Placid, FL		
1983	John A. Stevens, Orlando, FL		
1984	John A. Stevens, Orlando, FL		
1985	John A. Stevens, Orlando, FL		
1986	John A. Stevens, Orlando, FL		
1987	John A. Stevens, Orlando, FL		



## PRO Category's APBA Hall of Champions Inductees

Since 1974, the PRO Category has selected two drivers each year for induction into the APBA Hall of Champions. A formula, based upon the driver's success during the year, considers World and National Championships won, National High Point Championships won, and records set during the season, and guides the PRO Commission in the selection. The formula is published in the APBA Rule Book. Past PRO Category inductees to the APBA Hall of Champions are:

1974	Jerry Simison, Fergus Falls, MN Doug Martin, Anaheim, CA	2000	Jamie Nilsen, Auburn, WA Buddy Tennell, Lawrenceville, GA
1975	Ralph Donald, Marietta, GA Lee Sutter, Jr., Waukesha, WI	2001	Paul Fuchslin, Dixon, CA Steve Greaves, Seattle, WA
1976	Jerry Kirts, Elkhart, IN Bruce Nicholson, Slidell, LA	2002	Tim Brinkman, Springfield, IL Jonathan Nilsen, Edgewood, WA
1977	Hal Tolford, Seattle, WA Bruce Nicholson, Slidell, LA	2003	Chris Hellsten, Orlando, FL Curt Hellsten, Orlando, FL
1978	Bruce Nicholson, Slidell, LA James Stone, Orange Park, FL	2004	Chris Hellsten, Orlando, FL Allen Thorsen, Newberg, OR
1979	Todd Brinkman, Springfield, IL Tom Kirts, Bristol, IN	2005	Jim Nilsen, Edgewood, WA Brandon Thirlby, Traverse City, MI
1980	Pete Hellsten, Savannah, GA Jerry Kirts, Bristol, IN	2006	Jim Nilsen, Edgewood, WA George Thornhill, Tacoma, WA
1981	Denny Henderson, Garland, TX Jack Kugler, Hamilton, IL	2007	Jim Nilsen, Edgewood, WA Brandon Thirlby, Traverse City, MI
1982	Jerry Kirts, Bristol, IN Larry Latta, Fort Lauderdale, FL	2008	Jim Nilsen, Edgewood, WA Tim Small, Lighthouse Point, FL
1983	John Stevens, Orlando, FL Chris Hellsten, Savannah, GA	2009	Sean McKean, Mabank, TX Jim Nilsen, Edgewood, WA
1984	Lee Bartolomei, Castro Valley, CA John Stevens, Orlando, FL	2010	Sean McKean, Mabank, TX Jim Nilsen, Edgewood, WA
1985	Dan Kirts, Bristol, IN Tom Kirts, Bristol, IN	2011	Doug Hall, De Kalb, MO Jim Nilsen, Edgewood, WA
1986	Todd Brinkman, Jr., Springfield, IL Bill Van Steenwyk, Barnhart, MO	2012	Jay Walls, Jr., Danville, IN Amy Nydahl, Bristol, WI
1987	Craig Harris, Savannah, GA John Stevens, Orlando, FL	2013	Jay Walls, Jr., Danville, IN Michael Thirlby, Interlochen, MI
1988	Larry Conner, McAllister, OK Joseph E. Garrick, Sr., Ocoee, FL	2014	Jay Walls, Jr., Danville, IN Jim Nilsen, Edgewood, WA
1989	Denny Henderson, Garland, TX Eddie Thirlby, Grawn, MI	2015	Jay Walls, Jr., Danville, IN Jim Nilsen, Edgewood, WA
1990	Bill Rucker, Jr., Oakdale, CA Dan Kirts, Bristol, IN	2016	Andrew Thirlby, Interlochen, MI Ryan Gowin, Kent, WA
1991	Steve Greaves, Seattle, WA Dan Kirts, Bristol, IN		Jim Nilsen, Edgewood, WA
1992	Denny Henderson, Garland, TX Dan Kirts, Bristol, IN		
1993	Steve Greaves, Seattle, WA George Thornhill, Tacoma, WA		
1994	Steve Greaves, Seattle, WA David Hooten, Bartow, FL		
1995	Dan Kirts, Bristol, IN George Thornhill, Tacoma, WA		
1996	Steve Greaves, Seattle, WA Chris Hellsten, Orlando, FL		
1997	Jack Campbell, Jr., Culver, IN Eddie Thirlby, Grawn, MI		
1998	Steve Greaves, Seattle, WA Eddie Thirlby, Grawn, MI		
1999	Steve Greaves, Seattle, WA Chris Hellsten, Orlando, FL Sean McKean, Irving, TX		



## George H. Townsend Medal

The George H. Townsend Medal has been awarded by the PRO Category since the 1930's. Until 2006, the medal was awarded to the PRO driver who was awarded the most points during the season in all PRO classes raced. The medal was thus awarded typically to the winner of the Col. Green Round Hill Trophy.

Beginning in 2006, the PRO Commission changed the criteria for the George H. Townsend Medal. In order to encourage and reward young participation in the PRO Category, the medal was awarded to the driver who totals the most points in the K PRO Hydro class during the season.

The **George H. Townsend --- K PRO Hydro Medal** winners are:

2006	Amy Eldredge, Malabar, FL
2007	Wendy Eldredge, Malabar, FL
2008	Ashley Rucker, Mountlake Terrace, WA
2009	Ashley Rucker, Mountlake Terrace, WA
2010	Colin Rucker, Mountlake Terrace, WA
2011	Ryan Thompson, Renton, WA
2012	Colin Rucker, Mountlake Terrace, WA
2013	Ryan Thompson, Renton, WA
2014	Jacob Mauldin, Friday Harbor, WA
2015	Travis Ulsh, Eatonville, WA
2016	Ryan Gowin, Kent, WA



## Gilbert Petermann Award

Gilbert "Gibby" Petermann raced outboards for over 50 years well into his 80's. Gibby was a gentleman racer as well as an innovative and creative motor builder who loved racing the 250cc Hydro class.

Following his passing, Gibby's fellow racers established the Gilbert Petermann Award to commemorate Gibby's contributions to outboard racing. The plaque is presented each year to the National High Point winner in the 250cc Hydro class.

The Gilbert Petermann Award winners are:

1998	David Eldredge
1999	Chris Hellsten, Orlando, FL
2000	Chris Hellsten, Orlando, FL
2001	Chris Hellsten, Orlando, FL
2002	Chris Hellsten, Orlando, FL
2003	Chris Hellsten, Orlando, FL
2004	Chris Hellsten, Orlando, FL
2005	Ben Thompson, Orlando, FL
2006	Chris Hellsten, Orlando, FL
2007	Brandon Thirlby, Traverse City, MI
2008	Billy R. Allen, Quincy, MA
2009	Billy R. Allen, Quincy, MA
2010	Michael W. Schmidt, Durham, CT
2011	Michael W. Schmidt, Durham, CT
2012	Amy Nydahl, Bristol, WI
2013	Chris Hellsten, Orlando, FL
2014	Chris Hellsten, Orlando, FL
2015	Chris Hellsten, Orlando, FL
2016	Chris Hellsten, Orlando, FL



## The Gary Wyhoski PRO Officials Award

In 2006 the PRO Commission established a special annual award called the PRO Officials Award. It is awarded each year by the PRO Commission to one or more individuals who have served the PRO Category in an official capacity. Beginning with the 2014 award, the PRO Commission renamed the award "The Gary Wyhoski PRO Officials Award" in honor of the late Gary Wyhoski who served as the flagger at the PRO Nationals for many years (see photo below).

The **PRO Officials Award** winners are:

- |      |   |
|------|---|
| 2006 | Paul Bosnich II, DePue, IL<br>R. C. Hawie, Lake Hamilton, FL<br>Steve Litzell, Marietta, GA |
| 2007 | Gary Wyhoski, Menasha, WI   |
| 2008 | Penny Anderson, Edmonds, WA<br>Kristi Ellison, Fayetteville, NC                             |
| 2009 | Steve Greaves, Seattle, WA  |
| 2010 | Fred Mason, Saginaw, MI   |
| 2011 | Ray Rodda, Carmel, IN   |
| 2012 | The folks who raised Lake DePue and saved the PRO Nationals                                 |
| 2013 | Kristi Ellison, Fayetteville, NC  |
| 2014 | Joyce Golley and Jerry Davids, Sr., Hampton, VA   |
| 2015 | Tom Burwinkle, Kingston, TN   |
| 2016 | The Tennell Family, Buford, GA  |



## PRO Category's Organization

The PRO Category is one of several racing categories within the APBA. The PRO Category is governed by the PRO Commission under the powers granted to it under the APBA by-laws. The PRO Commission members are elected from each region where PRO racing is active to 1-year terms. The Commission selects the PRO Chairman for a 2-year term. The Chairman may appoint additional Commissioners.

The Commission typically meets twice per year, once at the PRO Nationals and once at the APBA Annual Meeting. At other times, the Commission conducts business by phone, fax, and email. The PRO Chairman appoints several committees to advise the Commission.

The PRO Commission acts as a single body to govern the activities involved in PRO racing. Such activities may include: discipline, new classes, appeals from rulings of race committees and referees, technical rule change proposals, safety rule changes, national championship site selection, maintenance of the championship officials list, and approval of records.

Safety rule and technical specification changes may be made by the Commission and are effective 30 days after publication in the APBA "Propeller" magazine. Technical class rules are changed by a vote of those drivers involved in the class.

The PRO Commission, along with the Category's various Committees and Championship Officials, are listed on the following pages.



**2017 PRO Commission**

Kristi Ellison, 2016-2017 PRO Chairman (Region 7)  
E918 Cherneyville Road  
Luxemburg, WI 54217  
Cell: 910-551-5752  
Email: parroth222@aol.com

J. David Augustine, Sr. (Region 4)  
323 Old Line Avenue  
Laurel, MD 20724  
Home: 301-725-2122  
Cell: 301-318-3683  
Email: patndave51@gmail.com

Rich Fuchslin (at large)  
265 North Almond St.  
Dixon, CA 95620-3301  
Cell: 916-425-5794  
Email: rfuchslin@gyttja.com

Steve Greaves (at large)  
3110 Portage Bay Place East  
Seattle, WA 98102-3884  
Cell: 206-371-0486  
Fax: 206-329-4952  
Email: sgreaves@portagebaysystems.com

David Jones (Region 1)  
254 Beaver Hill Road  
North Windham, CT 06256-1236  
Cell: 860-778-3541  
Work: 860-565-3501  
Email: dmj-dmj-32-d@att.net

Dwight Malhiot (Region 10)  
279 Gold Creek Road NW  
Bremerton, WA 98312-9634  
Cell: 360-731-3835  
Home: 360-830-4978  
Shop: 360-415-9027  
Email: dmalhiot@wavecable.com

J W Myers (at large)  
6443 NE 196th.  
Kenmore, WA 98028  
Cell: 206-271-6400  
Email: Jdub47R@gmail.com

Jim Nilsen (Region 10)  
3210 - 89<sup>th</sup> Ave E  
Edgewood, WA 98371-1982  
Cell: 253-709-0200  
Email: jnilsen529@comcast.net

Mike Thirlby (Region 6)  
10114 Creighton Road SW  
Fife Lake, MI 49633-9416  
Work: 231-946-0595  
Cell: 231-590-7855  
mthirlby@thirlbyautomotive.com

---

## 2017 PRO Committees

### PRO Chief Referee

Jim Nilsen

### PRO Chief Inspector

David Augustine, Sr.

### PRO Motor Advisory Committee

Dwight Malhiot

Mike Thirlby

Chris Hellsten

Mike Wienandt

### PRO Safety Committee

Rich Fuchslin

Kristi Ellison

David Jones

Bob Wartinger

### PRO Boat Advisory Committee

Derek Gessler

Mike Krier

Zach Malhiot

Gary Pugh

### K PRO Hydro Committee

Mike Thirlby

Jim Nilsen

### C Service / C Racing Technical Committee

Jay T. Walls

Dwight Malhiot

Mike Thirlby

Karl Williams

Jack Campbell, Sr.

### PRO UIM Committee

Chris Hellsten

Fred Hauenstein

Bob Wartinger

### PRO Awards Committee

George Thornhill

Steve Greaves

Kristi Ellison

### PRO Nationals Committee

Kristi Ellison

Mike Thirlby

J W Myers

Jim Nilsen

Steve Greaves

### PRO Membership Growth Committee

Mike Thirlby

Dwight Malhiot

J W Myers

Zach Malhiot

Chris Hellsten

### PRO Technical Manual Committee

Steve Greaves

Kristi Ellison

## PRO Championship Referees, Scorers, and Inspectors

The following table shows Referees, Scorers, and Inspectors who have been approved by the PRO Commission for service at Championship and Record regattas. To serve these officials must also meet any APBA requirements for their role. The codes indicate that the official is approved for serving at Divisionals ("D"), Nationals ("N"), Worlds ("W"), and/or Record ("R") races.

	D	N	W	R
<b>Referees, Eastern Division</b>				
Ian Augustine	D	N	W	R
Dee Berghauer	D	N	W	R
Josh Kimble		N		
Tom McCain	D			R
Howie Nichols	D	N		R
Connie Payn	D	N		
Doug Rea				R
Steve Roskowski	D			
Bernie Van Osdale	D	N	W	R
Mark Weber				R
Mark Wheeler	D	N	W	R
<b>Referees, Western Division</b>				
Gloria Crim				R
Sam Houghtaling	D	N	W	R
Jean MacKay-Schwartz	D	N	W	R
Jim Nilsen	D	N	W	R
Susan Rautenberg	D	N	W	R
Sheryl Rucker	D			R
Rick Sandstorm	D	N	W	R
Howard Shaw	D	N		R
Allen Thorsen	D	N	W	R
Teri Ziemer	D			R
<b>Scorers, Eastern Division</b>				
Suzette Burkhart	D			R
Linda Eldredge	D	N	W	R
Jill Glossner	D	N		R
Joyce Golley		N		
Lisa Jennings	D	N		R
Darleen Nuccio	D	N		R
Aimie Pond	D			
Donna Roskowski	D			
Ann Marie Shaw				R
Harriett Thompson	D	N		R
Annette Weber	D	N	W	R



<b>Scorers, Western Division</b>				
Kay Boyes	D	N		R
Carol Dodge	D			R
Ann Hoban	D			R
Laurie Gowin	D			
Sheri Greaves	D	N	W	R
Denise Johnson	D			
Lisa Peterson	D	N		R
Jean Mackay-Schwartz	D	N		R
Jan Shaw	D			R
Laureen Thorsen	D			R
Linda Thorsen	D			R
Pat Yarno	D			R
<b>Inspectors, Eastern Division *</b>				
David Augustine, Sr.	D	N		R
David Brill	D			R
Bill Breaux	D			R
Jack Campbell, Jr.	D			
Jerry Davids, Jr.	D			
Jerry Davids, Sr.	D	N		
Marshall Eldredge, Jr.	D	N	W	R
R. C. Hawie	D	N	W	R
James G. Johnson	D			
Tom Johnston	D	N	W	R
Roger Przybyla	D			R
Ed Runne	D	N	W	R
Mike Schmidt	D	N	W	R
John Snell	D	N	W	R
Mike Wienandt	D	N	W	R
Jeff Williams	D	N		R
<b>Inspectors, Western Division *</b>				
Roger Carr	D	N	W	R
Steve Greaves	D	N	W	R
Joe Johnson	D	N	W	R
John Laird	D			R
Carl Lewis	D			R
Joel Policar	D			
George Thornhill	D	N	W	R
Allen Thorsen	D	N	W	R
Dave Tonge	D			R
Steve Wilde	D			R

- Any approved Stock Category Inspector is approved to inspect KPH or OSY400 for records.

## PRO Classes

The PRO Category offers racing in nineteen separate classes. In addition to the class name, the following table shows the class abbreviation and the class number. The abbreviations are often used as a shorthand designation for the class, and the class number is used by APBA for high point tabulation.

Class Name	Class Abbreviation	Class Number
125cc Runabout	125R	04010
250cc Runabout	250R	04020
350cc Runabout	350R	04030
500cc Runabout	500R	04040
700cc Runabout	700R	04180
1100cc Runabout	1100R	04060
C Service Runabout	CSerR	04120
C Racing Runabout	CRacR	04140
K PRO Hydro	KPH	04190
125cc Hydro	125H	04200
175cc Hydro	175H	04280
250cc Hydro	250H	04210
350cc Hydro	350H	04220
500cc Hydro	500H	04230
700cc Hydro	700H	04240
1100cc Hydro	1100H	04260
OSY400	OSY400	04320
C Service Hydro	CSerH	04330
C Racing Hydro	CRacH	04340



## PRO Class Participation

The following table shows the class participation nationally during the years 1992 through 2016. A participant is defined as a driver who made a start in the class during the season.

Class	'92	'93	'94	'95	'96	'97	'98	'99	'00	'01	'02	'03	'04
125cc Runabout											6	7	10
250cc Runabout	18	11	14	8	14	15	15	13	10	11	14	12	13
350cc Runabout	13	14	10	12	13	12	14	11	15	11	15	14	11
500cc Runabout	10	16	10	12	17	13	12	20	31	20	17	15	20
1100cc Runabout	25	23	18	16	17	20	20	16	23	14	16	15	15
C Service Runabout	24	23	24	23	27	23	23	23	19	19	20	19	19
C Racing Runabout	19	20	17	16	24	20	21	21	14	13	15	16	21
J / K PRO Hydro	11	9	23	13	17	14	20	23	45	44	45	35	23
125cc Hydro	11	17	14	14	16	20	21	24	21	16	21	19	25
250cc Hydro	46	37	40	33	27	25	22	38	27	22	29	22	32
350cc Hydro	45	49	46	41	42	36	38	42	37	29	36	30	29
500cc Hydro	88	64	57	47	42	36	14	15	15	8	11	13	12
500cc Sprint Hydro											12	6	3
700cc Hydro	44	30	27	34	23	17	16	16	16	5	10	8	8
1100cc Hydro	44	25	14	15	11	4	9	16	12	5	7	6	9
RB Hydro / 175cc Hydro	50	47	36	20	20	7	14	9	14	15	14	9	9
Novice 350 / OSY400	44	16	34	37	47	47	58	73	96	82	88	86	90
C Service Hydro	17	15	17	14	14	14	19	17	13	16	14	13	12
C Racing Hydro	13	19	15	18	14	13	17	15	12	13	13	13	15
Total	522	435	416	373	385	336	353	392	420	343	403	358	376

Class	'05	'06	'07	'08	'09	'10	'11	'12	'13	'14	'15	'16
125cc Runabout	13	11	13	7	15	13	7	8	2	0	0	0
250cc Runabout	15	13	13	10	10	13	10	9	0	0	0	0
350cc Runabout	13	17	14	11	12	16	10	13	0	4	0	0
500cc Runabout	21	23	12	16	15	16	14	14	6	13	10	3
1100cc Runabout	15	14	8	14	15	10	5	12	6	5	4	8
C Service Runabout	20	20	18	17	21	19	17	17	15	13	13	14
C Racing Runabout	18	16	16	14	15	17	16	16	15	11	12	11
J / K PRO Hydro	16	21	20	28	28	25	13	22	10	9	14	16
125cc Hydro	23	24	31	26	33	34	29	27	18	19	14	12
250cc Hydro	34	28	25	21	27	28	22	17	11	5	5	4
350cc Hydro	27	24	26	24	20	25	21	22	12	13	8	8
500cc Hydro	14	16	13	11	8	10	10	8	0	0	0	0
500cc Sprint H / 175ccR / 700R	6	8	5	7	0	0	4	3	0	0	12	4
700cc Hydro	6	12	9	6	5	9	9	6	0	5	0	0
1100cc Hydro	11	14	16	13	10	12	13	11	0	5	0	0
RB Hydro / 175cc Hydro	6	5	8	6	15	22	14	14	3	10	6	4
Novice 350 / OSY400	85	73	70	71	71	71	56	48	34	38	42	33
C Service Hydro	14	14	13	15	14	14	14	13	9	12	11	9
C Racing Hydro	12	16	14	11	12	14	12	10	11	10	11	7
Total	369	369	344	328	346	368	296	290	152	172	163	133

- The Novice 350 class became the OSY400 class beginning in 1994.
- Reinforced cockpits were required in 700cc Hydro beginning in 1996.
- Reinforced cockpits were required in 1100cc Hydro beginning in 1997.
- Reinforced cockpits were required in 500cc Hydro beginning in 1998.
- The 125cc Runabout and 500cc Sprint Hydro classes were first introduced mid-season during 2002.
- Beginning in 2003, the J PRO Hydro class was renamed to K PRO Hydro.
- Beginning in 2004, the word "Antique" was dropped from the C Service and C Racing class names.
- Beginning in the 2006 season, RB Hydro became 175cc Hydro.
- Beginning in the 2009 season, 500 Sprint Hydro became 175cc Runabout.
- OSY400 for the 2012 season required a minimum weight and jetty starts.
- Beginning in the 2014 season, OSY400 required a minimum weight.
- Beginning in the 2015 season, 175R was replaced with 700R.

## PRO Safety Rules

### Safety Summary

The PRO Category has several safety requirements in addition to those specified by the general APBA Safety Rules.

1. Flak jackets (or impact material within the life jacket) must be worn.
2. An automatic shut-off throttle and an ignition kill switch tethered to the driver are required.
3. A positive method of stopping the motor must be accessible from the normal driving position.
4. Steering cable arrangements may not include "S" hooks.
5. Steering cable anchors must be bolted through with backing plates or washers of at least 3/4" diameter.
6. Magneto flywheels require a flywheel guard.
7. Carburetor spray shields are required except for rear-facing carburetors or while running in straightaway time trials.
8. A paddle must be carried in the boat.
9. The ignition cutoff tether must be attached to the driver via a wrist strap with a "D" ring or to the life jacket.
10. Drivers must wear long pants while testing or racing.
11. Unless the driver is restrained, the driver must be able to exit the cockpit without moving or removing any windshields, canopies, or cockpit cowlings.
12. Runabout fins may not protrude more than 1" beyond the chine.
13. Hydro fins may not protrude beyond the maximum beam of the boat.
14. The use of cut-resistant ankle length pants and full length cut-resistant sleeves while racing or testing is required. Drivers of reinforced cockpit boats are exempt.
15. Helmet restraints are recommended in PRO racing.

### Safety Summary for Reinforced Cockpits

The PRO Category has several safety requirements related to reinforced cockpits in addition to those specified by the general APBA Safety Rules.

Boats racing in the 500ccH, 700ccH, and 1100ccH classes must utilize a reinforced cockpit with driver restraints. Step-ups, step-downs, and cross-overs must conform to the reinforced cockpit requirements of the class entered. Any PRO boat utilizing a driver restraint system shall have a reinforced cockpit according to the specifications below.

These rules provide only a minimum standard for reinforced cockpits. It is important that constructors continually develop cockpits beyond these minimums and produce cockpits that exceed these standards.

1. The manufacturer of any reinforced cockpit will submit his name (company name) and complete a PRO Reinforced Cockpit Questionnaire to the PRO Chairman before use of the cockpit in an APBA sanctioned regatta. The manufacturer's name, date of manufacture, and serial number must be permanently affixed to the reinforced cockpit.
2. The manufacturer will receive a letter of acknowledgement from the PRO Safety Committee, copies of which may be sent to the individual competitors.
3. Any competitor driving, or passenger, in a registered reinforced cockpit design boat will be in a restraint system consisting of a minimum 5-strap / 4-point mounting design. Strap locations will be minimum two hip, two shoulder, and crotch hooked together in a central release system activated (released) from the normal driving position. The use of a "lever-activated" central quick release system shall be mandatory. Belts shall be a minimum 2" width. These are the required placements of seat belts and shoulder harnesses to be used in a reinforced cockpit. (See drawing below.)

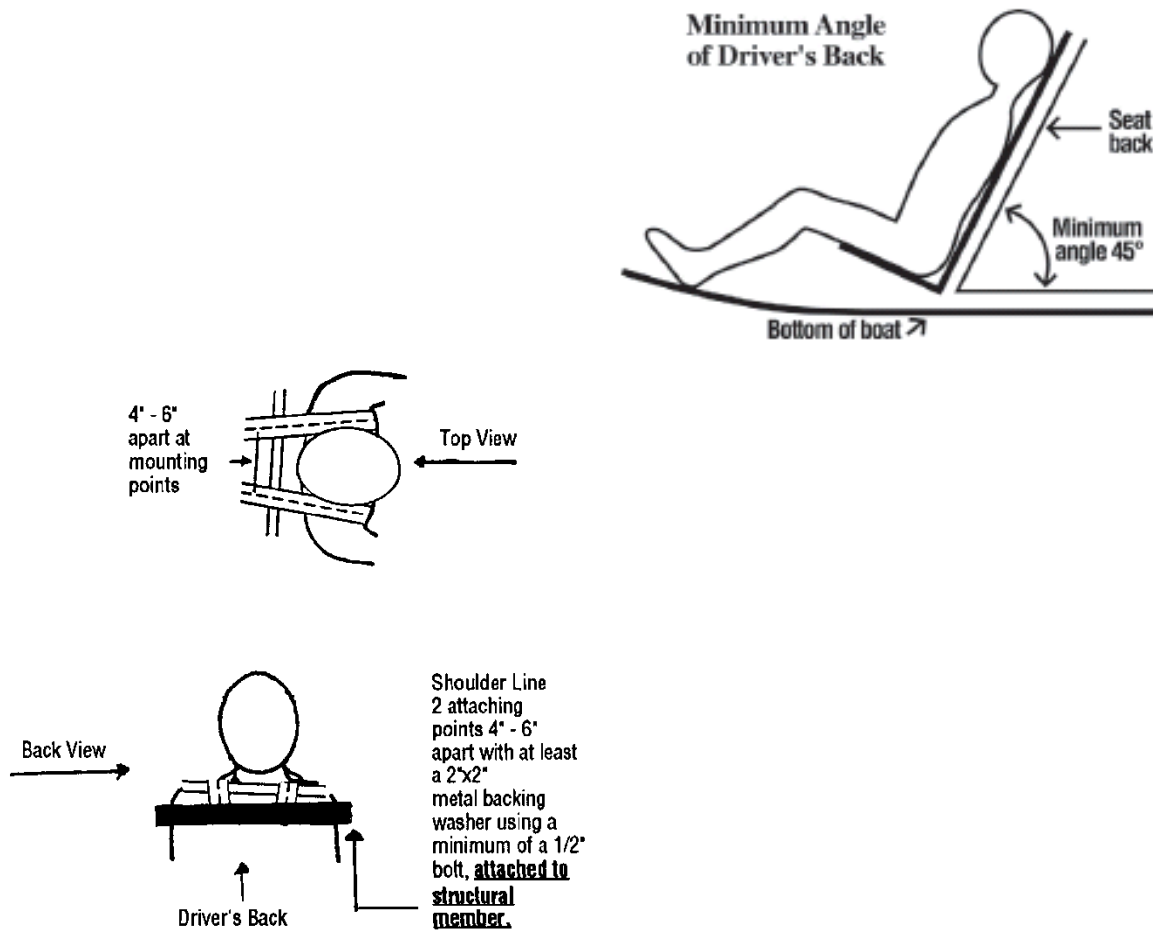

4. The boat must have enough buoyancy, either natural or from use of permanently attached flotation to float the combined hull, driver, and motor in a swamped state. Cockpit structure must also include permanent flotation capable of floating the cockpit, driver, engine and any other attached structures. Placement shall be in the closest possible location to the rear of the driver (cockpit) and the sides of the driver (boat). Two (2) pound per cubic foot, closed cell, U.S.C.G. approved flotation is recommended.
5. All reinforced cockpits must include coverage over at least 50% of the top of the driver's helmet with a minimum of 2" clearance above the driver's head and coverage over at least 50% of the side of the driver's helmet with the driver's head in the furthest aft position, as an integral part of the cockpit construction. It is recommended that in a reinforced cockpit, an opening of at least nine (9) square inches be made in the seat/backboard, behind the driver's helmet, so as to reduce the hydraulic effect on the driver in case of an accident.
6. A minimum of 1/4" Ethofoam (1/2" recommended) or other energy absorbing foam must be present completely around the inside of the helmet area to help prevent injury from the helmet hitting the cockpit.
7. Reinforced cockpit boats using an electric fuel pump or fuel injection must have an additional centrifugal-force-actuated or inversion-actuated kill switch. This switch must be capable of disabling the engine ignition as well as the electric fuel pump, if so equipped, when the boat is upside down.
8. Reinforced cockpit boats using full coverage canopies and/or cowlings must have both internal and external release capabilities for driver's exit, as well as positive airflow ventilation. The canopy must have one or more external handles or hand-holds to facilitate opening of the canopy

- from the outside. All canopy attaching hinges must have an easily removable hinge pin utilizing a pull ring, assessable from outside the cockpit. It is recommended that all canopy attaching hinges also have an internal release mechanism.
9. Left and right rear view mirrors are required. Mirrors are to be minimum of eight (8) square inches. Mirrors are not required during kilo trials.
  10. No sharp edges or protrusions are allowed anywhere inside or around the entryway of the cockpit.
  11. It is required that the top of the front of the cockpit should be a maximum of 4" below eye level and so constructed as to deflect water away from the driver.
  12. A removable steering wheel is highly recommended, "spring loaded".
  13. As a guide, the following construction methods have proven themselves effective in racing:  
Suggested construction:
    - Step 1 Gel cote mold and let dry.
    - Step 2 Apply ¾ oz. glass mat and let dry.
    - Step 3 Apply layer of 6 to 9 oz. carbon fiber or S-glass, layer of 9 oz. Kevlar, layer of veil, and a layer of 3/8" Belcobalsa core or equivalent density of foam.
    - Step 4 Apply a layer of veil, layer of 9 oz. Kevlar, layer of veil, and layer of 9 oz. carbon fiber. Vacuum bag and apply vacuum until fully cured.
    - Step 5 Capsule should be laminated with epoxy resin or vinyl ester resin.
  14. Ventilation is required in the driving compartment to prevent fogging and in the aft compartment to prevent an accumulation of fumes.
  15. Drivers in a reinforced cockpit must be restrained in a seated position. A "seated position" is defined as having the driver's chest and legs facing forward and no less than 45 degrees of angle between the driver's back and the bottom of the boat.
  16. When used in a capsule boat, life jackets do not need to meet the PRO requirement for flak material.
  17. Drivers in capsule boats are exempt from the requirement to carry paddles and exempt from the requirement to paddle off the course if stopped.
  18. Life jackets used in reinforced cockpit boats shall have adequate flotation for the driver.
  19. The use of an air supply system in reinforced cockpit boats is mandatory.
  20. Upon request of the Referee, drivers of reinforced cockpit boats are required to show written certification of having completed supervised underwater cockpit escape training within the prior two years. Such written certification shall be signed and dated by an APBA Referee or other APBA official having reviewed the training.
  21. To the degree practical, the seating system, whether upright or reclining, should provide lateral support on both the left and right sides. The driver should be positioned as far rearward and as close to the seat back bulkhead as possible. It is absolutely necessary, in the reclining position, to provide a kick-up (roll-up) forward to the buttocks of sufficient height and strength to prevent forward movement and/or rotation of the torso under the seatbelt. In the reclining position, adequate padding is recommended under the buttocks to absorb impact.



## Technical Class Rules

### General Technical Summary

The following general technical specifications apply to all classes in the PRO Category unless specifically superseded by a particular class's technical rules. These specifications summarize those areas of interest to participants and officials but do not cover every rule of PRO racing. The current APBA Rule Book should be used as the definitive reference on all class rules.

1. PRO racing boats shall be powered by one outboard motor.
2. An outboard motor may be any 2-cycle or 4-cycle reciprocating engine.
3. Superchargers are not allowed.
4. Tuned intake and exhaust is permitted.
5. A motor may have no more rotary valves than cylinders.
6. Propulsion must be by water propeller.
7. Propellers must push, not pull.
8. The lower unit's "S" dimension (see Motor Specification Diagrams) must be at least .625 inches.
9. The lower unit's "Q" dimension (see Motor Specification Diagrams) must be no more than 24.25 inches.
10. The propeller shaft to drive shaft angle may not exceed 100 degrees.
11. Any non-pressurized liquid fuel is permitted.
12. PRO boats must have a racing number strongly contrasting with the background color. PRO boats may have a racing number composed of only a number.

### Legal Motors

The legal motors for use in each class are detailed in the following table.

Class	Legal Motor
125cc Runabout & Hydro	Any single-cylinder motor up to and including 128.75cc
175cc Hydro	Any motor up to and including 175cc
250cc Runabout & Hydro	Any motor up to and including 257.5cc
350cc Runabout & Hydro	Any motor up to and including 350cc
500cc Runabout & Hydro	Any motor up to and including 500cc
700cc Runabout	Konig / Konny rotary-valve motors over 500cc up to and including 710cc
700cc Hydro	Any motor up to and including 700cc
1100cc Runabout & Hydro	Any motor up to and including 1133cc
K PRO Hydro	Mercury 60J, OMC J/A, Mercury J/A
OSY400	Yamato 80, Yamato 102, Yamato 202, Yamato 300 series
C Service Runabout & Hydro	OMC Speeditwin, Johnson P-50, Johnson PX-50, Johnson PO
C Racing Runabout & Hydro	Johnson PR, Evinrude Racing C, Hubbell Racing C

## 4-Stroke Maximum Displacement Table

The classes listed below have a maximum displacement range for 4-stroke motors that is 1.5 times the maximum displacement for 2-stroke motors. The table below shows the maximum displacement range for 2-stroke and 4-stroke motors in each class.

Class	2-stroke maximum cc's	4-stroke maximum cc's
125ccR	128.75	193.13
250ccR	257.5	386.25
350ccR	350	525
500ccR	500	750
1100ccR	1,133	1,699.5
125ccH	128.75	193.13
175ccH	175	262.5
250ccH	257.5	386.25
350ccH	350	525
500ccH	500	750
700ccH	700	1050
1100ccH	1,133	1,699.5





## Driver's Age

The following table describes the age requirements for drivers in the various PRO classes.

Class Name	Minimum Age Requirement
125cc Runabout	14 years
125cc Hydro	14 years
175cc Hydro	16 years
250cc Runabout	16 years
250cc Hydro	16 years
350cc Runabout	16 years
350cc Hydro	18 years
500cc Runabout	18 years
500cc Hydro	18 years
700cc Runabout	18 years
700cc Hydro	18 years
1100cc Runabout	Driver: 18 years Deck Rider: 16 years
1100cc Hydro	18 years
K PRO Hydro	11 - 16 years *
OSY400	14 years
C Service Runabout	14 years
C Service Hydro	14 years
C Racing Runabout	16 years
C Racing Hydro	16 years

\* Drivers may not compete in KPH after the end of the racing season in which they turn 16 years of age.

## Minimum Runabout Lengths

The following table describes the minimum length of runabouts in the PRO Category (the C Service and C Racing Runabout classes have additional design restrictions listed later in this manual).

Class Name	Minimum Runabout Length
125cc Runabout	11' 6"
250cc Runabout	11' 6"
350cc Runabout	12'
500cc Runabout	13'
700cc Runabout	13'
1100cc Runabout	13'
C Service Runabout	13'
C Racing Runabout	13'

## Runabout Restrictions

1. The PRO runabout racing hull must conform to the following:
  - a. The bottom shall have no steps or breaks in the longitudinal continuity.
  - b. The bottom must not have any of the following:
    - i. Tunnel
    - ii. A concavity greater than one-sixteenth (1/16) of an inch within the planning surface
    - iii. Any design that uses a tunnel effect
  - c. The side of the boat must form a continuous contour from a single stem to transom and must have no concavity greater than one-quarter (1/4) inch. For all classes except the C Service and C Racing classes, the "side" of the boat referred to in Section "c" shall be interpreted as the outside chine.
  - d. Trim tabs which are adjustable by the driver while underway shall not be allowed.
  - e. Rub rails will be allowed provided:
    - i. They are attached to the extreme outside of the boat, and
    - ii. They do not exceed 1.5" in depth and width.
2. Runabout lengths as specified in class rules shall be measured from top of transom along centerline to tip of bow excluding any hardware or other devices added to the boat to extend its overall length.

## Hydroplane Restrictions

Sponsons on PRO hydroplanes shall not exceed 60% of the hull length.



## Displacement-based Classes

### Additional Class Restrictions

The following listed classes, sometimes known as "Bore and Stroke Classes", are generally unrestricted. This means that for these "unrestricted" classes, there are only the restrictions detailed in the previous "General Technical Summary", piston displacement, hull requirements, driver age requirements, and any additional class restrictions listed below.

Class	Additional Class Restriction(s)
125cc Runabout	125cc motors may only have one cylinder
125cc Hydro	125cc motors may only have one cylinder
175cc Hydro	None
250cc Runabout	None
250cc Hydro	None
350cc Runabout	None
350cc Hydro	None
500cc Runabout	None
500cc Hydro	Boats competing in the 500ccH class must utilize a reinforced cockpit with driver restraints.
700cc Runabout	Konig / Konny rotary-valve motors only
700cc Hydro	Boats competing in the 700ccH class must utilize a reinforced cockpit with driver restraints.
1100cc Runabout	The 1100ccR class requires two persons in the boat: a driver and a deck rider.
1100cc Hydro	Boats competing in the 1100ccH class must utilize a reinforced cockpit with driver restraints.



## Stock and Mod Motors (Cross-overs and Step-downs)

Motors legal for APBA's Stock and Mod Categories are also legal in the PRO Category's displacement-based classes. When these motors are run in their comparable PRO class based upon their piston displacement, they are referred to as "cross-overs" meaning that they have crossed over from their comparable Stock or Mod class.

At non-championship and non-record events, certain older motors, which utilize deflector scavenging, are allowed to run in a smaller class than their displacement. These motors are called "deflector step-downs".

The following table shows many motors utilized in the J, Stock and Mod categories and the unrestricted PRO classes where they are allowed to run as a "Cross-over" and/or as a "Deflector Step-down".

Stock or Mod Motor	"Cross-over" PRO Class	"Deflector Step-down" PRO Class	Stock Class	Mod Class	Cubic inches	CC's
OMC J/A	250		J, AS	FA	13.2	216.31
Mercury KG4H	250			AM	14.9	244.17
Mercury Mark 15	250			AM	14.9	244.17
Hot Rod A	250			AM	14.94	244.82
Mercury J/A	350	250	J, AS		15.6	260.55
Mercury 20H	350	250		BM	19.9	326.10
Hot Rod B	350	250		BM	19.94	326.76
Yamato 80	350		20SS	BM	19.99	327.58
Mercury 25SS	500	350	25SS	25M	22	360.51
Mercury 200	500	350		25M	22	360.51
OMC 22.1	500	350		25M	22.1	362.15
Yamato 102	500		CS	CM	24	393.29
Yamato 202	500				24	393.29
Yamato 300 series	500		CS		24	393.29
Mercury 25XS	500		25SS		24.4	399.84
Mercury 30H	500	350		CM	30	491.61
Mercury 55H	700	500		DM	39.6	648.93
Mercury 44XS	1100	500, 700	DS		43.9	719.39
Mercury 44	1100	500, 700		DM, FE	43.9	719.39
OMC 45SS	1100		45SS	FE	44.9	735.78
OMC 75	1100			FE	49.7	814.43
Mercury 650XS	1100	700		FE	49.9	817.71
Mercury 6 cyl	1100	700		FE	60	983.22
Merc 650	1100	700		FE	66.5	1089.74

## Motor-based and Restricted Classes

The following classes have additional technical restrictions.

### K PRO Hydro

#### 1. Motors (The following are approved legal motors for use in the KPH class.)

- a. Mercury 60J
- b. OMC J/A 13.2 cu. in.
- c. Mercury 15 (15.9 cu. in. produced in 1999 or later)

**Note: While the motor specifications presented herein are intended to be accurate, it is also the intention that the motor specifications for the OMC J/A and the Mercury 15 be identical to those for the J Classes. Should any motor specification differences exist for the OMC J/A and the Mercury 15 presented herein and those of the J Classes, the motor specifications for the J Classes shall prevail.**

#### 2. Mercury 60J Motor Rules

- a. Motor must be run with the factory cowl without modifications if motor was manufactured with a cowling. It must be run with the usual manufacturer's markings.
- b. Tuned exhaust must be totally within the towerhousing without modifications.
- c. The factory crankcase and cylinder block must be used with a single carburetor. Modifications are permitted provided they do not conflict with general or safety rules.
- d. The bore and stroke must be per factory specifications.
- e. Motors may be modified for burning alcohol.

#### 3. OMC J/A and Mercury 15 Motor Rules (also see additional specifications below)

- a. The engine shall retain the factory colors and decals, with the following exceptions:
  - 1) The power head may be either painted or unpainted. If it is painted, the color must be the same as the original color.
  - 2) Gear cases must be painted original factory colors or have no paint. Unpainted gear cases may be polished.
- b. The engine shall be operated with the production upper and lower motor covers installed and supplied by the manufacturer. Air inlets into cowlings must remain closed as in original factory condition, either with plugs or with tape.
- c. The mounting of a fuel tank to the engine or steering bar is prohibited.
- d. Any type or make of spark plug is permissible.
- e. Adjustable high-speed carburetor jets are not permissible. Larger or smaller fixed jets are permissible.
- f. The addition or removal of material from the flywheel is prohibited.
- g. Polishing or removal of material on the carburetor, or exhaust system is prohibited.
- h. Broken parts may be repaired by welding or use of plastic compound, if all contour and dimensions remain as original. Broken skegs and cavitation plates may be used provided that the edges of the break or breaks have not been filed or smoothed or otherwise altered.
- i. It is permissible to repair stripped threads by tapping oversize, or using helicoils, or using threaded inserts.
- j. The addition of engine thrust brackets is permissible.
- k. Any make or type of bolt, nut, screw, stud or washer may be used (with the exception of the butterfly screw), provided it does not require alteration of the engine to permit its use.
- l. It is permissible to secure the impeller to the prop shaft by any means.
- m. Internal machined surfaces may be re-machined so long as minimum and maximum dimensions are met. Cast or forged surfaces must remain as cast with no alterations, bead blasting, media blasting, or polishing. It is not permissible to re-machine surfaces that do not have specific dimensions. The reed plate openings are cast surfaces and must remain as cast.
- n. The prop shaft location shall be no higher than 1-3/4" below the boat bottom. The measurement of the prop shaft location shall be the distance between the center of the prop shaft at its aft end and the boat bottom as defined herein. The measurement of the engine height shall be "as raced" with the engine turned straight (prop shaft in line with the fore aft centerline of the boat). The boat

bottom shall be measured relative to the lowest planing surface at the aft end of the boat. This restriction shall apply to all racing including straightaway trials.

- o. Electric starters shall be permissible.
  - p. No restrictor plate is required.
  - q. The motor shall utilize gas and oil fuel conforming to the APBA Modified Category specifications.
- r. OMC J/A Motor Rules**
- 1) On the OMC J/A motors, safety wires must be in place from the steering bar-power head bolts. Drivers will be warned once before being disqualified.
  - 2) It is permissible to use non-OEM steering bars, steering bar brackets and throttle linkages. No modifications to the carburetor are permitted.
  - 3) Boyesen Reeds part no. 122 shall be legal replacement parts.
  - 4) It shall be allowable to plug off the “water slot hole” with dimensions Z and Z1 in the engine specifications. It is also allowable to plug the small hole that is at the top of the water passage around the exhaust ports that has no dimensions in the engine specifications.
  - 5) The use of genuine OMC/BMC oversize pistons and rings is permissible.
  - 6) Port openings may have plastic compound added for repair.

**s. Mercury 15 Motor Rules**

- 1) It is not permissible to use non-APBA steering bars, steering bar brackets, and throttle linkage.
- 2) The carburetor butterflies shall be replaced with APBA Part J55.
- 3) It is permissible to replace the upper and lower rubber tower housing bushings with APBA Part J56.
- 4) It is permissible to place fuel cell material (foam) in the carburetor or utilize the APBA baffle.
- 5) It is permissible to remove the thermostat and to restrict the water in any manner within the thermostat housing.
- 6) It is permissible to remove the transom cleats located on the stern bracket.
- 7) The use of genuine Mercury oversized pistons and rings are permissible.
- 8) It is permissible to remove the OEM fuel connector.
- 9) It is permissible to add a throttle stop to the carburetor.
- 10) It is permissible to use Mariner engines that meet all Mercury specifications.
- 11) It is permissible to use aftermarket or modified motor mounts. The driveshaft housing and brackets may not be modified to accept aftermarket or modified motor mounts.
- 12) It is permissible to close the hole in the service carburetor butterfly with solder or epoxy.
- 13) It is permissible to use any bearing or seal.
- 14) It is permissible to hone connecting rods as long as all specifications are met.
- 15) It is permissible to hone the center main bearing shell as long as all specifications are met.
- 16) It is permissible to use any Bowden cable clamp when electric start is used.
- 17) It is permissible to use Mercury’s “High Energy Ignition Kit” (Mercury part number: 339-7370A40).

**4. Boats:**

The boat shall be hydroplane type without weight restrictions. Sponsons must not exceed 60% of the hull. Any hull that meets the definition of a PRO runabout may not compete in K PRO Hydro.

**5. Other:**

Drivers in the KPH class having less than four prior races in APBA competition must wear a white “X” on their helmets and are restricted to starting and racing “in the outside lanes of the course” and “at the rear of the field”. The helmet “X” requirement and the driving restrictions outlined above apply to all drivers under the age of 12 regardless of any prior racing experience. (The “X” must have a stroke of at least 1.5” in width and must extend from ear to ear and from front to back, intersecting at the top of the helmet.)

**OMC J/A Motor Specifications**

Engine Model	Johnson	JKT		
	Evinrude	EKT		
Volume of Combustion Chamber at TDC to top of Spark Plug Hole	Min. cc	13.5		
Number of Cylinders			2	
Cylinder Bore Diameter	Standard	G	2.188 (ref. only)	
	0.010 O.S.		2.198 (ref. only)	
	0.030 O.S.		2.218 (ref. only)	
	Max. O.S.		2.225 Max.	
Crank Stroke		J	1.760+/-0.008	
Rod Length		L	3.000+/-0.006	
Piston Dimension		E	3.918+/-0.010	
		F	1.868+/-0.010	
		G	0.642+/-0.014	
Piston Rings	Number per Piston		2	
	Material		Cast Iron	
	Thickness	Upper		0.068+/-0.002
		Lower		0.062+/-0.002
	Design	Upper		Pressure Back
		Lower		Rectangular
	Free Diameter	Upper		2.235+/-0.025
Lower			2.335 +0.030 / -0.070	
No. of Ports per Cylinder	Transfer		3 round holes	
	Exhaust		3 round holes	
Port Height	Transfer	A	3.480 maximum	
	Transfer	A3	3.490 maximum	
	Exhaust	C	3.680 maximum	
Port Dimension * Lynco gauges shall be used	Transfer	A1	0.625+/-0.010 Dia.*	
	Exhaust	C1	0.625+/-0.015 Dia.*	
	Transfer	A2	0.625+/-0.025 Dia.*	
	Exhaust	C2	0.625+/-0.025 Dia.*	
Cylinder Height		K	4.880+/-0.015	
Cylinder Width		K1	4.520+/-0.025	
Crankcase Height		K2	1.830+/-0.020	
Intake Manifold Height			1.040+/-0.025	
Reed Block (One per Cylinder)	Reed Material		Stainless steel or plastic	
	Reed Thickness		0.011+/-0.0005	
	Shim Thickness		0.012+/-0.001	
	Reed Stop Height	H	0.256+/-0.020	
	Reed Stop Radius	H1	5.000+/-0.500	
	Checking Distance	Y	1.260+/-0.030	
	Port Location	N	1.430+/-0.015	
	Port Length	N1	1.010+/-0.030	
	Port Width (Dia.)	N2	0.675+/-0.025	
Cylinder Base		X	1.056 minimum	
Flywheel Weight			5lbs. 4oz. minimum	
Carburetor	Venturi Diameter		0.875+/-0.005	
	Bore Diameter		1.000+/-0.005	
Exhaust Specifications	Meg. Length	U	10.633+/-0.050	
		U1	10.510+/-0.050	
	Meg. Relief Hole (Dia.)	T	0.280+/-0.020	
	Inside Exhaust Outlet Holes	D	0.880+/-0.020 Dia.	
		D1	0.500+/-0.020 Dia.	
	Housing Relief Holes		0.310+/-0.020 Dia.	
	Water Relief Hole	P	0.040+/-0.010 Dia.	
Gear Case Specifications	Impeller Blades		5	
	Gear Ratio		14:19	
		Q	11.550+/-0.200	
	Q1	9.100+/-0.200		
	R	2.050 minimum		
	S	0.980 minimum		
	W	4.765+/-0.020		
W1	4.340+/-0.100			
Bearing Specifications	V		18.000+/-0.060	
	1		Roller	

		2	Roller
		3	Ball
		4	Roller w/retainer
		5	Roller
		6	Roller
		7	Roller / roller thrust
		8	Roller / roller thrust
		9	Roller / roller



OMC J/A Motor Specification Diagrams

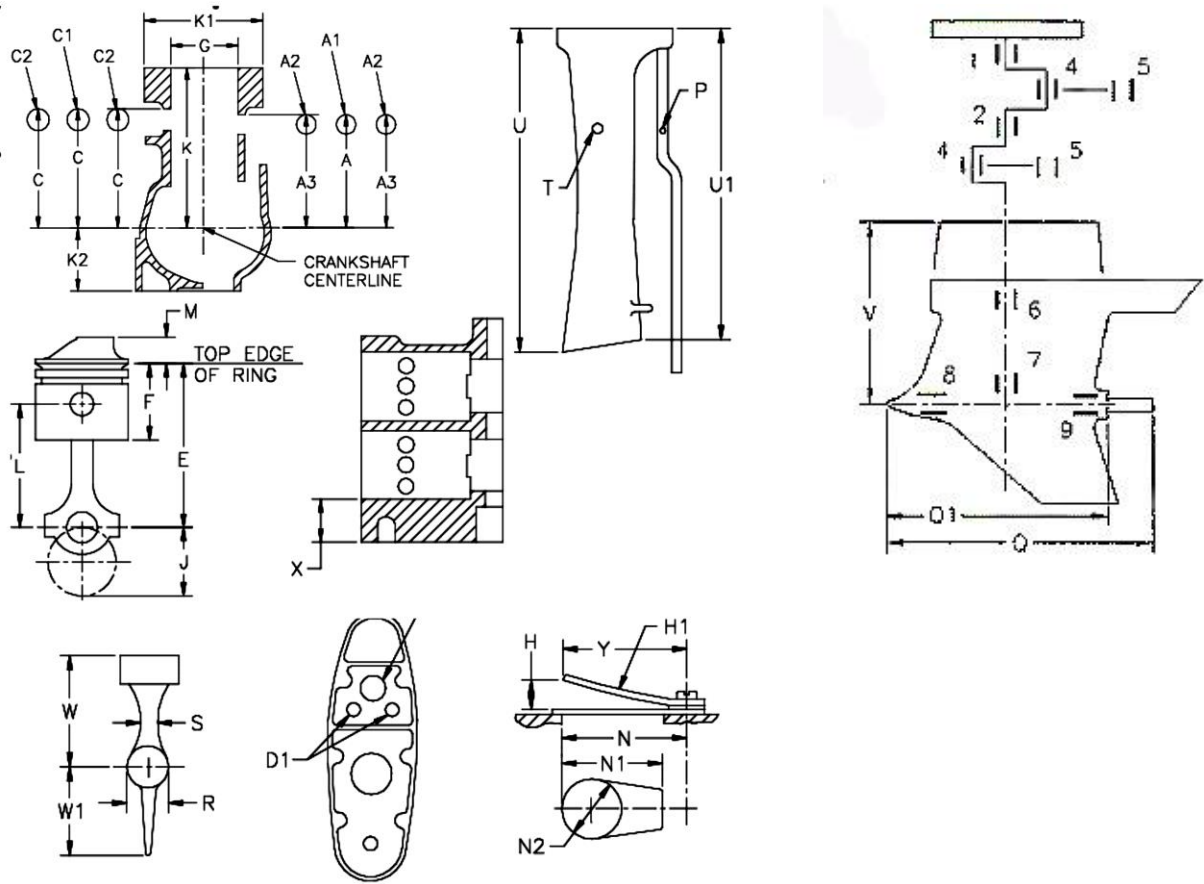

**Mercury 15 Motor Specifications**

Item		Reference	Specification
Displacement	CID		15.9
No. of cylinders			2
Compr. Vol. @ TDC	Min. cc		16.00
Transfer Ports	Timing	A	3.640+/-0.015
	Height	A1	0.630+/-0.010
	Width		0.950+/-0.020
Exhaust Ports	Timing	C	3.781+/-0.015
	Height	C1	0.630+/-0.010
Cylinder #1	Width		1x0.900; 1x0.950+/-0.020
Cylinder #2	Width		2x0.950+/-0.020
Port Edge Radius			0.020 maximum
Exhaust Relief Hole		C	4.305+/-0.020
	Width/Height	C1	0.195+/-0.010
Comb. Ch. Corner Ht.		H	5.713+/-0.010
Cylinder Bore	(ref)	G	2.376
	Max.	G	2.41
Stroke		J	1.800+/-0.010
Piston	Material		Aluminum
	Deck Ht.	E	4.180+/-0.015
	Defl. Ht.	E1	0.563+/-0.005
	Total Ht.	F	2.653+/-0.030
Conn. Rod Length		L	3.100+/-0.005
Reed Block	No. opens	Per cyl.	3
	Length	M	0.906+/-0.015
	Width	N	0.510+/-0.015
	Stop Ht.	P	0.325 maximum
	Stop Lt.	P1	1.23 minimum
	Petal th.	O	0.008+/-0.002
Flywheel Weight	Lbs/oz.		7.9 lbs minimum
Carburetor	Venturi		1.000+/-0.010
	Boost Vent.		N/a
	Throat		1.130+/-0.010
Exh. Adapter & Pipe		D	13.280+/-0.125
Gear Case Specs			Same as OMC A specs (Also see below)
DSHSG		V	16.000+/-0.250
GC Adapter Height			0.500+/-0.010

Mercury 15 Motor Specification Diagram

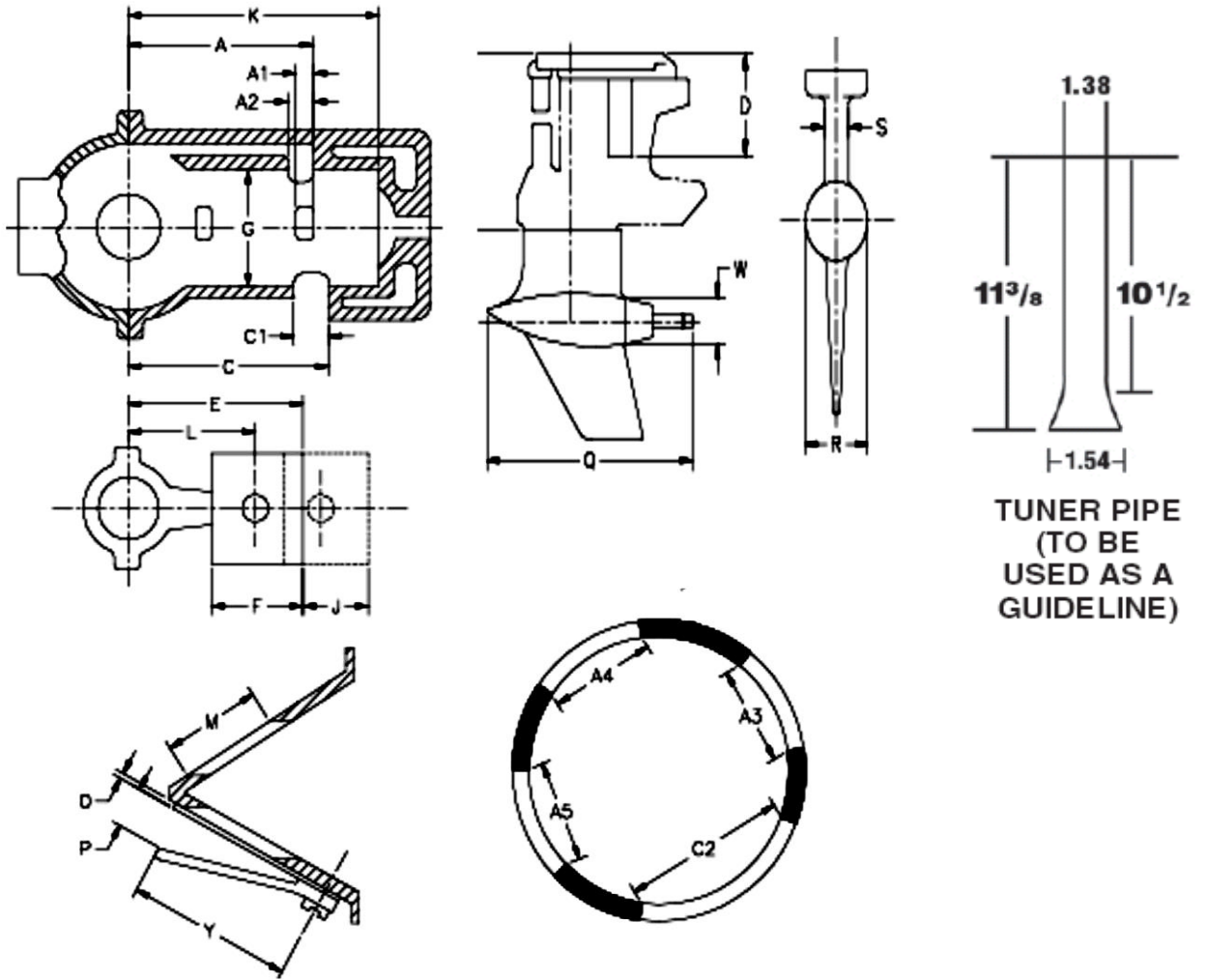

## OSY400

### Motors:

Yamato 80, Yamato 102, Yamato 202, Yamato 300 Series

**Note: While the motor specifications presented herein are intended to be accurate, it is also the intention that the motor specifications for the Yamato 80, 102, and 300 series be identical to those for the Stock Category C Stock class. Should any motor specification differences exist for the Yamato 80, 102, and 300 series presented herein and those of the Stock Category C Stock class, the motor specifications for the Stock Category C Stock class shall prevail.**

### Class Technical Rules:

1. The boat shall be hydroplane type without weight restrictions. Sponsons must not exceed 60% of the hull. Any hull that meets the definition of a PRO runabout may not compete in the OSY400 class.
2. The following motors are legal:
  - a. A Yamato 80 which meets the rules and specifications below.
  - b. A Yamato 102 which meets the rules and specifications below.
  - c. A Yamato 202D or 202E which meets the rules and specifications below.
  - d. A Yamato 300 series which meets the rules and specifications below.
3. Must use gas and oil fuel that meets the APBA Modified Category requirements for fuel.
4. Must not change the motor height or angle while underway.
5. The class shall have a minimum overall weight of 396 lbs.

### Yamato 80 Motor Rules

1. No use of parts other than Yamato 80 parts are allowed, except as approved herein.
2. Any make of spray shield may be used. It is permissible to use any make of gaskets (other than head gasket), bearings, seals, ignition components, piston rings, or prop shaft, provided no engine modifications are made to accommodate them.
3. Any make of prop shaft may be used. The minimum diameter shall be 9/16". Only one shear pin hole is permissible. This allows the fabrication of a new 9/16" prop shaft without the forward shear pin hole. The fabricated shaft will be similar to the original but is not required to use metric threads.
4. It is permissible to enlarge the fuel tank or build a complete new tank. If the tank is removed, the tank mounting brackets may also be removed.
5. A fuel pump may be used for racing, but the carburetor shall not be modified in any way.
6. It is permissible to remove the timing knob. The magneto stator plate may be fixed in position on the crankcase by any means.
7. Any type of thrust bracket adjustment is allowed. It is permissible to drill 2 holes at the front of the cavitation plate to facilitate the mounting of a thrust bracket block.
8. Any fuel line or fittings are permissible provided the threads in the fuel tank and on the carburetor are not changed. A fuel filter may be used.
9. No polishing or removal of metal on any internal passages of the carburetor, intake manifold, crankcase, exhaust bypass, or tuned exhaust system is allowed. Bead blasting, sand blasting, or blasting by any other media of any internal engine components is not permissible.
10. A metal head gasket is mandatory (0.5 mm or 1 mm size only).
11. No modifications are permitted to reed port openings or reeds.
12. It is legal to bore the cylinders one size larger bore size than the standard bore.
13. It is permissible to resleeve any block provided engine specifications are maintained.
14. No expanding or knurling of pistons is permitted.
15. The Yamato carburetor butterfly must remain intact. No thinning or tapering is allowed.
16. Except for the butterfly screw, any type, size, or make of nut, bolt, screw, or washer may be used.
17. No balancing of reciprocating or rotating parts is allowed.

18. There shall be no substitution of components such as lower units, carburetors, etc. unless replacement components are specifically designated as legal for a particular model by the PRO Commission.
19. No drilling or modifications of any type, except repair, may be done on the water jackets to change the cooling pattern.
20. It is permissible to grind, file, or polish the lower unit as long as all dimensions and templates are met. The "bulge" may be ground flush with the sides of the skeg.
21. Drilling of water drain holes in the ignition casting (coil plate and crankcase end cap) is permissible, and these holes may be tapped and plugged.
22. One or two water outlet tube(s) on Y-80 are permissible.
23. To measure the Q dimension, lightly depress the reed against the reed block. Next, measure between the top of the reed and the bottom edge of the reed stop. (NOTE: Do not remove the shim from under the reed.)
24. In order to compensate for the removal of the "bulge" from gear cases, Inspectors should add an extra 0.275 inches to the template to properly measure a gear case without the "bulge".
25. It is permissible to use non-OEM crank pins and exhaust stacks. (The inspector may compare to new.)
26. The water inlet holes may be repaired with weld or plastic compounds. Water inlet hole diameter 0.270 – 0.297. Contours and shape must be as originally manufactured.
27. If fuel tank is removed, the tank mounting brackets may also be removed.
28. It is legal to re-machining the squish band area to match Mod rule angle  $15^\circ \pm 2^\circ$ ,  $2.350 \pm 0.015$ . No changes may be made to the combustion chamber. There must be a visible ledge surrounding the squish band.
29. Any aftermarket 14:16 gears may be used on the Y-80.
30. Any ignition coil may be used on the Y-80 and the mounting may be altered to accommodate the coil.

#### Yamato 80 Motor Specifications:

Description	Dimension	Yamato 80
Displacement (cubic inch)		20
Number of Cylinders		2
Volume of Combustion Chamber at TDC to Top of Spark Plug Hole	Cylinder Head	Minimum cc
	14 MM	18
	18 MM	18.5
Powerhead Specifications	A	5.980 – 6.024
	B	2.752 – 2.760
	C	3.885 – 3.906
	D	1.800 – 1.830
	D1	1.840 – 1.875
	E	1.420 – 1.460
	F – Gasket	0.010 – 0.020
	G – Gasket	0.016 – 0.040
	J (Cylinder Overbore)	2.387 maximum
	K	4.204 – 4.221
	KN	5.496 – 5.527
Reed Block 2 Sets (2 Leaves x 2)	L	2.322 – 2.402
	M	2.279 – 2.228
	Q	9/32 (0.281 maximum)
	Q1	1.350 – 1.420
	R1	0.012+/-0.002
Carburetor Milkuni BV-30	SR	0.006 – 0.009
	Venturi Dia.	0.984+/-0.015
	Butterfly Thickness	0.058+/-0.005
Flywheel Weight		2.86lbs. minimum
Exhaust Stack	P	10-5/8 Overall +/-1/16
	P2	4.724+/-0.050
	P4	1.614+/-0.050
	P5	2.598+/-0.050
	Exhaust Holes (2 holes)	0.788 x 0.850
Gear case	Gear Ratio	14:16
	O	18.464 – 18.622
	S	1.195 minimum
	T	8.465+/-0.100

	U	4.724+/-0.100
	V	11.340 maximum
	W	2.300 minimum
	X	2.874 – 3.031
	Y	3.267 – 3.425
	Z1	0.185 minimum
	Z2	0.185 minimum
	Z3	0.130 minimum
	Z4	0.130 minimum
	Z5	1.969+/-0.050
	CL	1.772 maximum
	CD	2.150 minimim
Bearings and Seals	1	Seal 25 x 40 mm
	2	Needle 30 x 30 mm
	3	Needle 28 x 35 mm
	4	Ball 25 x 55 mm
	5	Seal 25 x 38 mm
	6	Needle 28 x 35 mm
	7	Needle 15 x 20 mm
	8	Seal 16 x 30 mm
	9	Ball 15 x 35 mm
	10	Needle 17 x 24 mm
	11	Ball 15 x 35 mm
	12	Needle 17 x 30 mm
	13	Seal 16 x 30 mm

Yamato 80 Motor Diagrams

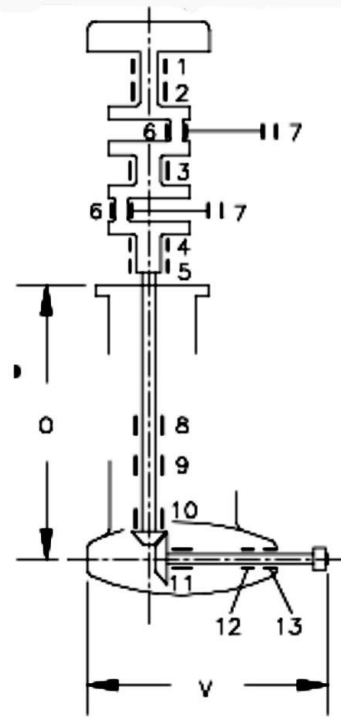
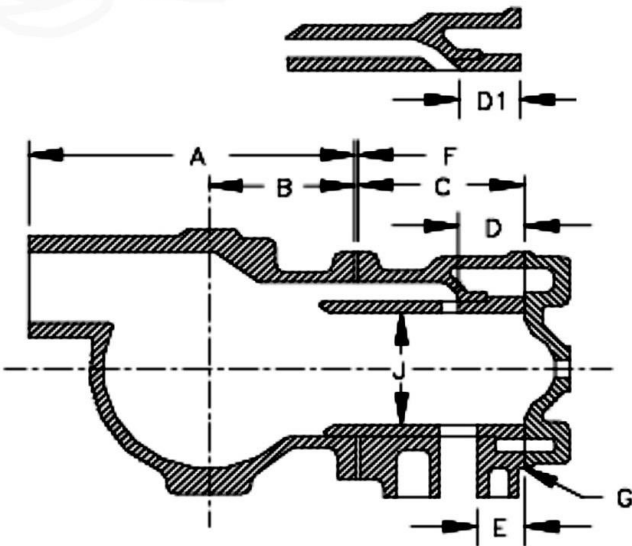
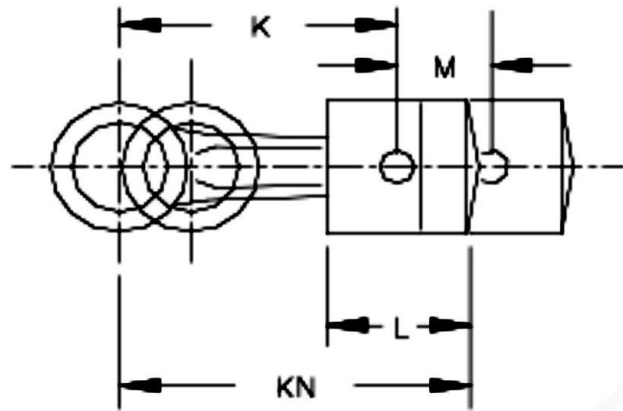
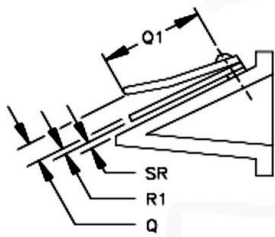

Yamato 80 Motor Diagrams (continued)

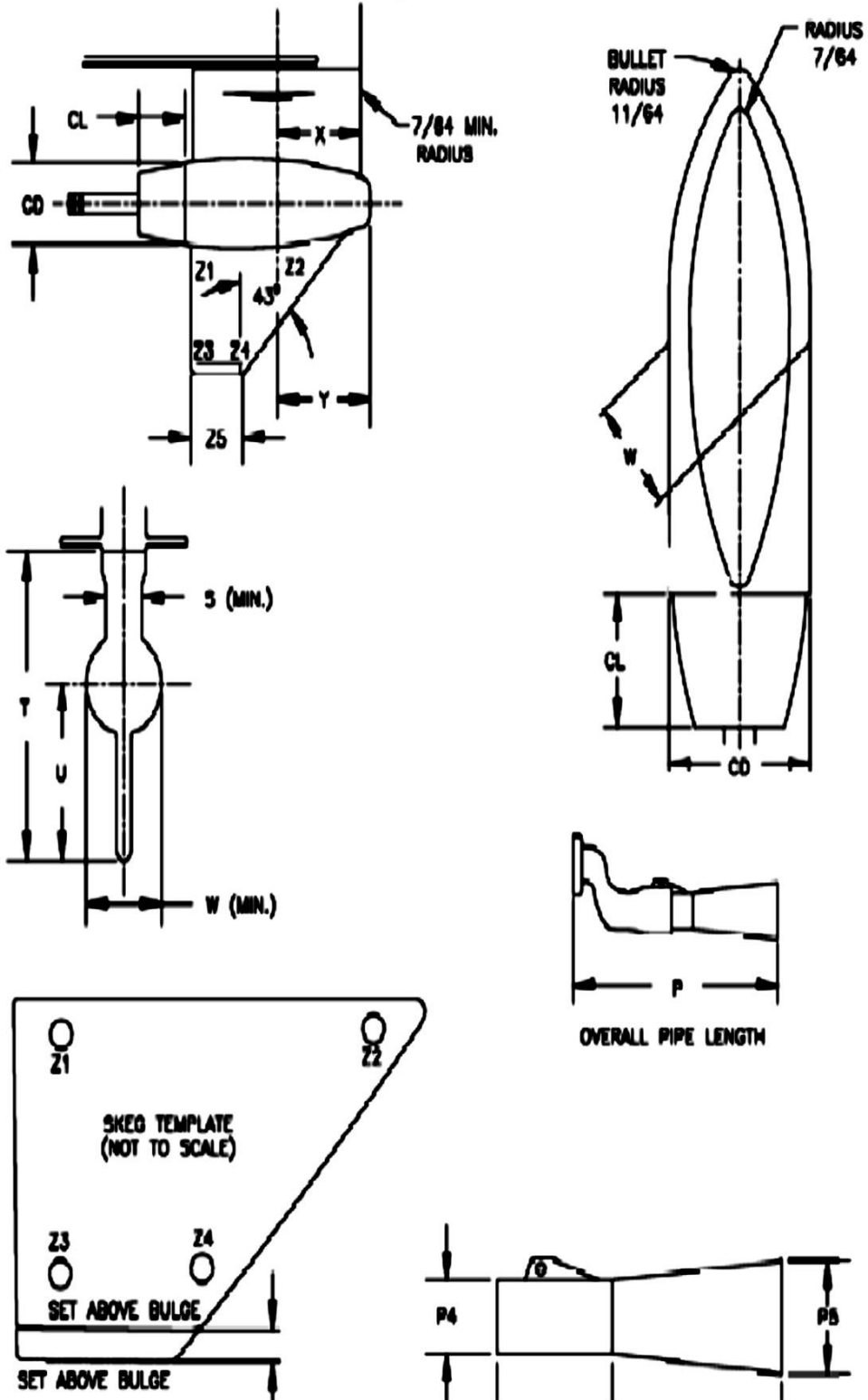



**Yamato 102, 202, and 300 Series Motor Rules**

The intent of these rules is for the Yamato 102, 202, 300 series engines to be raced as received from the manufacturer without modification except as specifically listed below. If a specific dimension is not listed in these rules, the Inspector may compare the dimensions of a new part to assist in making a decision regarding part legality.

**Permissible Modifications**

1. It is permissible to use any make of bearings, seals, ignition components, piston rings, steering bar, or prop shaft provided no engine modifications are made to accommodate them.
2. It is permissible to drill water drain holes in the ignition castings (coil plates and crankcase top end cap), and these holes may be tapped and plugged.
3. It is permissible to enlarge the fuel tank or build a complete new tank. If the tank is removed, the tank mounting brackets may also be removed. A fuel filter may be added to the fuel line.
4. A fuel pump may be used for racing, but the carburetor shall not be modified in any way.
5. It is permissible to grind, file, or polish the lower unit as long as all dimensions and templates are met. The "bulge" may be ground flush with the sides of the skeg on the 102, 202, and 300 .
6. Any type of thrust bracket adjustment is allowed. It is permissible to drill 2 holes at the front of the cavitation plate to facilitate the mounting of a thrust bracket block.
7. The tilt lock lever and spacer on the tilt bracket bolt may be removed.
8. The magneto stator plate may be locked in position by any means and the stator plate timing knob may be removed.
9. The spray shield may be modified for use with throttle cable to allow easier access for engine priming and it may be painted.
10. The prop shaft may be turned down to 9/16 inch minimum diameter or a new propeller shaft may be made (9/16 inch minimum diameter). In either case, only one shear pin hole is permissible. The prop nut thread size is optional.
11. It is legal to bore the Yamato 102, 202, and 300 series cylinders one size larger than standard bore. It is permissible to resleeve any block provided engine specifications are maintained.
12. It is permissible to mill the cylinder head within the H and I dimensions. No changes may be made to the combustion chamber. It is legal to re-machining the squish band for repair purposes only angle  $15^{\circ} \pm 2^{\circ}$ ,  $2.612 \pm 0.015$  for Y-102, Y-202, and Y-300 series engines. There must be a visible ledge surrounding the squish band.
13. It is permissible to substitute the Yamato 300 series gear case assembly for use on the 102 engine. The 102 gear case assembly may not be used on the 300 series engine.
14. The 102 exhaust megaphone may have any type of welding, gusset, strap, etc. used on the outside only, to repair or reinforce as long as all other dimensions are met. It will be left to the discretion of the inspector to decide if any changes to the inside of the megaphone were due to welding "melt through" or were done to intentionally change the interior configuration.
15. It is permissible to use non-OEM crank pins and exhaust stacks. (The inspector may compare to new).
16. The water inlet holes may be repaired with weld or plastic compounds. Water inlet hole diameter 0.270 – 0.297. Contours and shape must be as originally manufactured.
17. It is permissible to reposition the ring groove stop pin to allow the use of the Model 300 series piston in the 102.
18. It is permissible to use the Yamato Model 202 magneto on the Model 102.
19. It is permissible to remount any coil on the 102.
20. Aftermarket roping plate is legal on the 102 as long as it meets OEM dimensions.

**Non-Permissible Modifications**

1. No drilling or modifications of any type may be made to the cooling system. Extended length, flexible water outlet "dump" hoses are permissible however.
2. Addition or removal of metal on any cast or forged internal engine components, surfaces or passages including the intake system, carburetor, or exhaust system is prohibited. Honing of cylinder bores and connecting rods is permitted.
3. Bead blasting, sand blasting, or blasting by any other media of internal engine components is not permissible.

4. Addition or removal of material from any moving parts including the flywheel, crankshaft, and pistons is prohibited.
5. The two water outlet drain holes in the bottom of the cylinder block must not be restricted.

#### General

1. The volume of the combustion chamber will be measured with all the spark plugs and bushings removed without removing the cylinder head from the engine.
2. Only Yamato parts will be considered as legal replacement parts (except as specifically noted in these rules). This includes (but is not limited to) all engine components, gaskets, etc.
3. To measure the reed stop heights (Q): lightly depress the reed and the bottom edge of the end of the reed stop.
4. For identification of the legal model 102, the outside dimension of the exhaust cover is 3 3/16 inches wide.
5. The 300 series gear case assembly can be identified by the snap ring and metal plate on the rear outside of the prop shaft cone. Some gear cases were supplied by the manufacturer without oil fill plugs. It is not permissible to add oil fill plugs to these units. Also, it is not permissible to eliminate the oil fill plugs from gear cases that were furnished by the manufacturer with oil fill plugs.
6. In compensation for measuring the gear case skeg without the factory "bulge", an additional 0.250 inches should be added to existing gear case templates in order to properly measure a gear case without the "bulge".
7. The latest replacement Carburetor has been approved for use on the 102, 202, and 300 series.

#### Yamato 102C and 300 Series Motor Specifications:

Description	Dimension	Yamato 102	Yamato 300 Series
1. Displacement		24 cu. in.	
2. Ignition		magneto	
3. Number of cylinders		2	
4. Volume of combustion chamber	18mm head	26cc min.	
	14mm head	25.5cc min.	
5. Piston weight w/rings, wrist pin		260 grams min.	
Con rod weight with both bearing sets and washers		184 grams min.	191 grams min.
6. Starter pulley weight w/o bolts & washer		440 grams min.	
7. Crankshaft/rods/pistons assembly weight		5,200 grams min.	5,300 grams min.
8. Reed valve plate		8 holes	
Reed hole size		.793 x 1.041	
Reed thickness		.012 +/- .002	
Reed stop height	Q	.289 max.	
9. Carburetor	model	Mikuni BV-36	
	throat	1.407 +/- .012	1.407 +/- .012
	venturi	1.102 +/- .012	1.102 +/- .012
Gear ratio		14:15 helix cut	
10. Towerhousing water inlet hole		.281 max.	
11. Flywheel weight		1500 grams min.	
12. Powerhead specifications			
Crankcase width	A	2.550 +/- .010	
	B	2.545 +/- .010	
Block length	C	4.104 +/- .010	
Transfer ports	D	1.890 – 1.915	
	D1	1.855 – 1.900	
	D2	N/a	
	D3	N/a	
Exhaust ports	E	1.430 – 1.455	
	E1	N/a	
Block: water outlet holes near exhaust manifold		.118 +/- .002	
Block to case gasket thickness	F	.004 - .012	
Cylinder head gasket thickness	G	.020 +/- .004	
Cylinder head thickness	H (18mm)	1.224 - 1.280	
	I (14mm)	1.430 - 1.470	
Cylinder bore	J	2.625 max.	

Connecting rod length	K	4.204 - 4.221	
Piston length	L	2.322 - 2.402	
Crankshaft stroke length	M	2.286 +/- .010	
Piston dome height	N	1.291 +/- .010	
Towerhousing length	O	18.464 – 18.622	17.283 - 17.402
Exhaust megaphone length	P	11.625 +/- .050	10.118 – 10.354
Relief holes	P1	.203 dia. max.	.197 dia. max.
Outlet hole	P2	2.400 +/- .040	2.469 +/- .004
Inlet hole	P3	2.180 max.	1.772 max.
	P4	1.060 max.	1.575 max.
13. Gear case	S	1.195 min.	
	T	8.465 +/- .050	
	U	4.724 +/- .050	
	V	10.8 max.	
	W	2.205 min.	
	X	2.980 +/- .030	
	Y	50 degrees	
	Z1	.190 min.	
	Z2	.190 min.	
	Z3	.150 min.	
	Z4	.150 min.	
	Z5	1.949 min.	
	CD	2.115 min.	
	CL	1.772 max.	

**Yamato 202D and 202E Motor Specifications:**

Description	Dimension	Yamato 202D	Yamato 202E
1. Displacement		24 cu. in.	
2. Ignition		magneto	
3. Number of cylinders		2	
4. Volume of combustion chamber	18mm head	26cc min.	
	14mm head	25.5cc min.	
5. Piston weight w/rings, wrist pin		260 grams min.	
Con rod weight with both bearing sets and washers		184 grams min.	191 grams min.
6. Starter pulley weight w/o bolts & washer		440 grams min.	
7. Crankshaft/rods/pistons assembly weight		5,200 grams min.	5,300 grams min.
8. Reed valve plate		12 holes	
Reed hole size		.512 x 1.142 max.	
Reed thickness		.012 +/- .002	
Reed stop height	Q	.289 max.	
9. Carburetor	model	Mikuni BV-36	
	throat	1.418 +/- .003	1.407 +/- .012
	venturi	1.103 +/- .003	1.102 +/- .012
Gear ratio		14:15 helix cut	
10. Towerhousing water inlet hole		.281 max.	
11. Flywheel weight		1500 grams min.	
12. Powerhead specifications			
Crankcase width	A	2.827 - 2.843	
	B	2.539 - 2.251	
Block length	C	4.102 - 4.114	
Transfer ports	D	1.890 - 1.913	
	D1	1.772 - 1.827	
	D2	1.255 - 1.295	
	D3	.978 - 1.018	
Exhaust ports	E	1.380 - 1.402	
	E1	1.791 - 1.831	
Block: water outlet holes near exhaust manifold		.118 +/- .002	
Block to case gasket thickness	F	.004 - .012	
Cylinder head gasket thickness	G	.020 +/- .004	
Cylinder head thickness	H (18mm)	1.244 - 1.280	
	I (14mm)	1.430 - 1.470	
Cylinder bore	J	2.625 max.	

Connecting rod length	K	4.205 - 4.220	
Piston length	L	2.346 - 2.378	
Crankshaft stroke length	M	2.276 - 2.291	
Piston dome height	N	1.291 - 1.307	
Towerhousing length	O	18.464 – 18.622	17.283 - 17.402
Exhaust megaphone length	P	10.118 – 10.354	
Relief holes	P1	.197 dia. max.	
Outlet hole	P2	2.469 +/- .004	
Inlet hole	P3	1.772 x 1.575 max.	
13. Gear case	S	1.195 min.	
	T	8.415 - 8.515	
	U	4.674 - 4.774	
	V	10.8 max.	
	W	2.205 min.	
	X	2.980 +/- .030	
	Y	50 degrees	
	Z1	.190 min.	
	Z2	.190 min.	
	Z3	.150 min.	
	Z4	.150 min.	
	Z5	1.949 min.	
	CD	2.115 min.	
	CL	1.772 max.	

Yamato 102, 202, and 300 Series Motor Diagrams

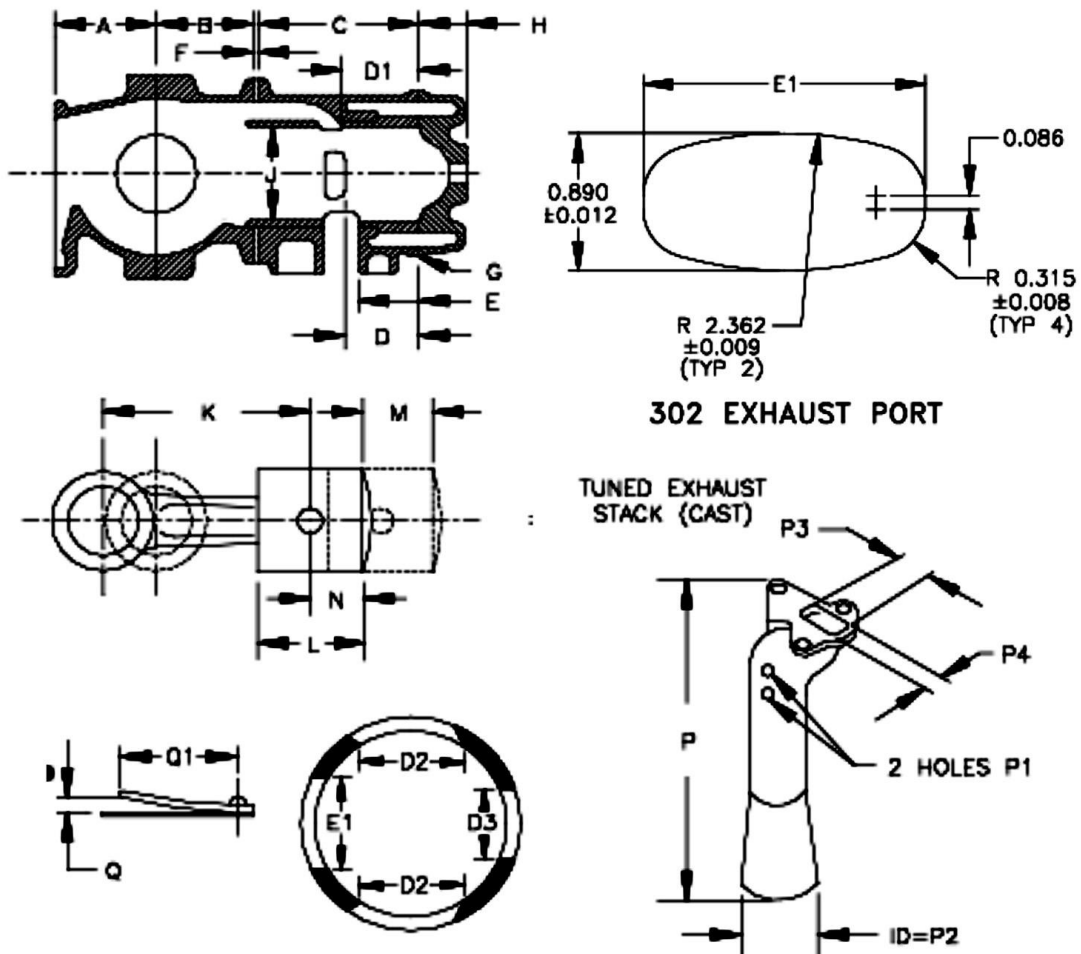

Yamato 102, 202, and 300 Series Motor Diagrams (continued)

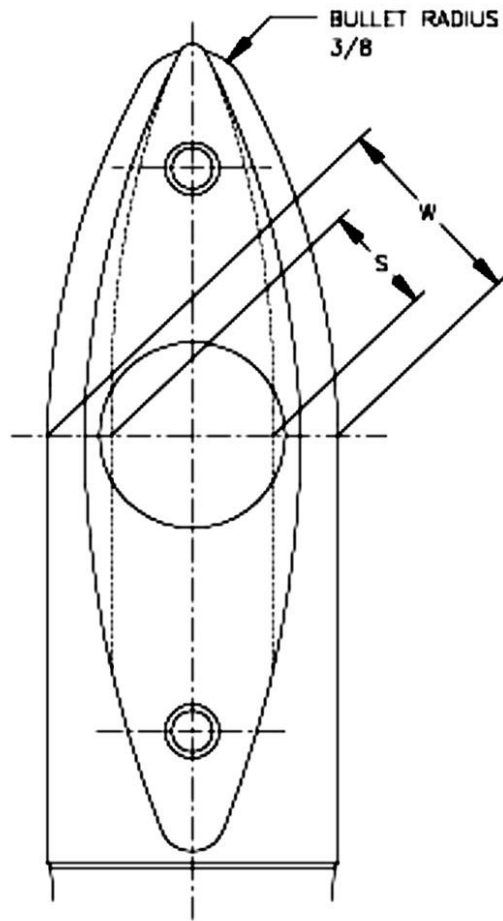
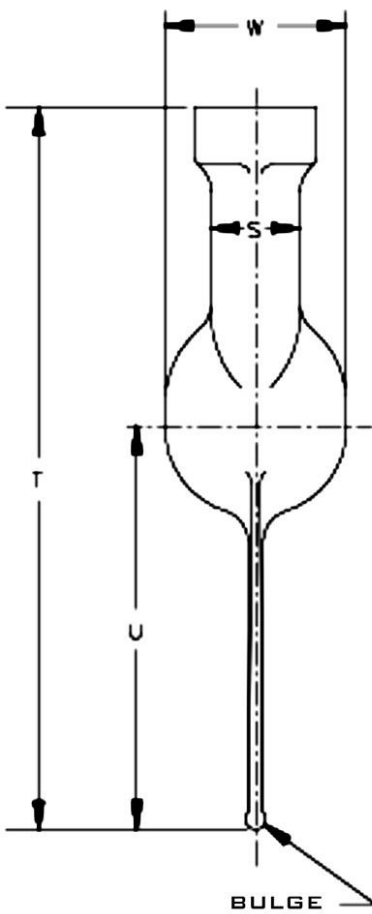
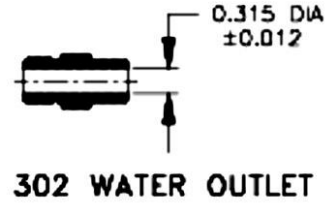
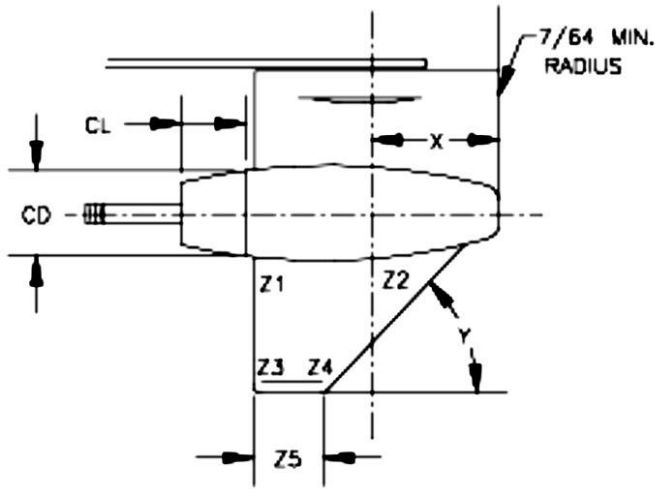

Yamato 102, 202, 300 Series Motor Diagrams (continued)

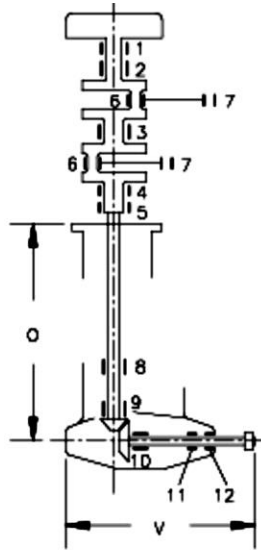
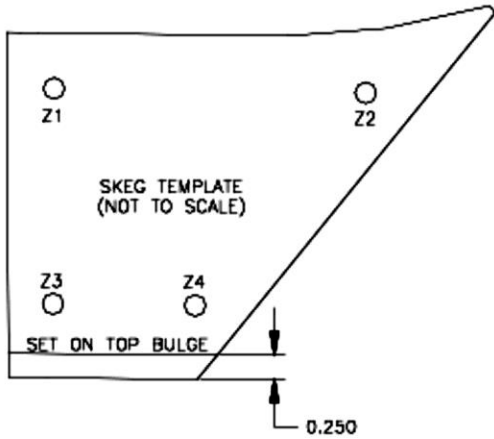

**YAMATO 302**  
ALTERNATE EXHAUST OUTLET CONFIGURATION  
(THIS MODIFICATION IS PERMISSIBLE FOR ALL 302 EXHAUST HOUSINGS. THE WATER INTAKE TUBE MUST BE RE-PLUGGED AT THE MACHINED SURFACE TO AVOID ENGINE DAMAGE)

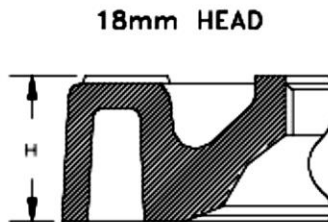
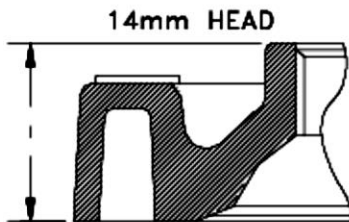
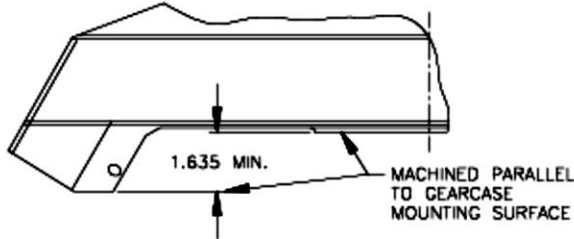

## C Service Runabout & Hydro

The C Service classes are based only upon the American-built fishing and pleasure outboard motors listed below and approved for use in the C Service classes during the 1930's, 40's, and 50's.

**Motors:** OMC (Evinrude / Elto) Speeditwin, Johnson P-50 & PX-50, Johnson PO

Motor	Code	OMC Speeditwin	Johnson P-50 & PX-50	Johnson PO
Displacement		30 cubic inches	30 cubic inches	30 cubic inches
Number of cylinders		2 cylinders	2 cylinders	2 cylinders
Firing of cylinders		Opposed	opposed	opposed
Gear ratio		14:21 or 15:21	12:21	12:21
Carburetor		Vacturi AO-500 or original carburetor	Vacturi AO-500	Vacturi AO-500
Dimensions (in inches)	A	2.828 +/- .030	2.828 +/- .063	5.068 +/- .026
	C	3.016 +/- .030	3.016 +/- .063	5.256 +/- .026
	E	2.375 +/- .030	2.328 +/- .063	4.568 +/- .031
	G	2.750 +/- .050	2.750 +/- .050	2.750 +/- .050
	H	5.000 +/- .018	4.480 +/- .015	
	J	2.500 +/- .016	2.515 +/- .015	2.514 +/- .002
	K	2.500 +/- .009	2.240 +/- .008	
	L	5.125 +/- .016	4.250 +/- .010	
	Q	13 3/8 maximum	12 15/16 maximum	12 15/16 maximum
	R	2 3/4 minimum	3 1/16 minimum	3 1/16 minimum
	S	15/16 minimum	1 7/32 minimum	1 7/32 minimum
X	3 1/8 maximum	1 7/32 minimum	1 7/32 minimum	
Z	4 5/8 maximum	5 1/2 maximum	5 1/2 maximum	
Other		13/16 x 2 5/16 maximum crankcase inlet	may use the PR-style crankcase, crankshaft, and connecting rods	

**Propeller Height:** The maximum distance that the propeller blade may extend above the bottom of the boat is specified below. (The bottom is measured from the true bottom, i.e., it is not measured from any tunnel.) The maximum propeller height restriction applies to all racing including straightaway trials.

Hull / Motor	Maximum Propeller Height
Runabout with OMC Speeditwin motor	1 inch
Runabout with Johnson motor	1-1/4 inches
Hydro with OMC Speeditwin motor	1-1/4 inches
Hydro with Johnson motor	1-5/8 inches

**Minimum Weights:** The C Service classes have a minimum weight that the entire outfit (boat, motor, driver, jacket, helmet, and remaining fuel, as raced, less any accumulated water) must weigh. The following table lists the minimum weights that apply to the C Service classes.

Class Name	Minimum Weight
C Service Runabout	500 lbs
C Service Hydro	450 lbs

## C Racing Runabout & Hydro

The C Racing classes are based only upon the American-built factory racing outboard motors listed below and approved for use in the C Racing classes during the 1930's, 40's, and 50's.

**Motors:** Johnson PR, Evinrude Racing C, Hubbell Racing C

Motor	Code	Johnson PR	Evinrude Racing C	Hubbell Racing C
Displacement		30 cubic inches	30 cubic inches	30 cubic inches
Number of cylinders		2 cylinders	2 cylinders	2 cylinders
Firing of cylinders		Opposed	opposed	opposed
Gear ratio		13:16 or 13:19	13:16 or 13:19	13:16 or 13:19
Carburetor		Vacturi AO-500	Vacturi AO-500	Vacturi AO-500
Dimensions (in inches)	A	2.859 +/- .063	2.859 +/- .063	2.859 +/- .063
	C	3.047 +/- .063	3.047 +/- .063	3.047 +/- .063
	E	2.328 +/- .063	2.328 +/- .063	2.328 +/- .063
	G	2.750 +/- .050	2.750 +/- .050	2.750 +/- .050
	H	4.490 +/- .025	4.490 +/- .025	4.490 +/- .025
	J	2.514 +/- .020	2.514 +/- .020	2.514 +/- .020
	L	4.250 +/- .020	4.250 +/- .020	4.250 +/- .020
	Q	13 7/8 maximum	13 7/8 maximum	13 7/8 maximum
	R	2 1/4 minimum	2 1/4 minimum	2 1/4 minimum
	S	11/16 minimum	11/16 minimum	11/16 minimum
Drive shaft housing length		12 7/8 minimum	12 7/8 minimum	12 7/8 minimum

**Propeller Height:** The maximum distance that the propeller blade may extend above the bottom of the boat is specified below. (The bottom is measured from the true bottom, i.e., it is not measured from any tunnel.) The maximum propeller height restriction applies to all racing including straightaway trials.

Hull	Maximum Propeller Height
Runabout	2 inches
Hydro	2 1/4 inches

**Minimum Weights:** The C Racing classes have a minimum weight that the entire outfit (boat, motor, driver, jacket, helmet, and remaining fuel, as raced, less any accumulated water) must weigh. The following table lists the minimum weights that apply to the C Racing classes.

Class Name	Minimum Weight
C Racing Runabout	500 lbs
C Racing Hydro	450 lbs



**Motor Specification Diagrams**

The following diagrams show the locations of the various "letter" specifications referred to in the Motor Specification Tables. Note: the "A" and "C" dimensions include the gasket, if any. If two adjoining surfaces both require the addition of gasket thickness to bring their measurements into tolerance, then multiple gaskets must be used. (Drawings created by Mike Cruver, Monroe, Washington.)

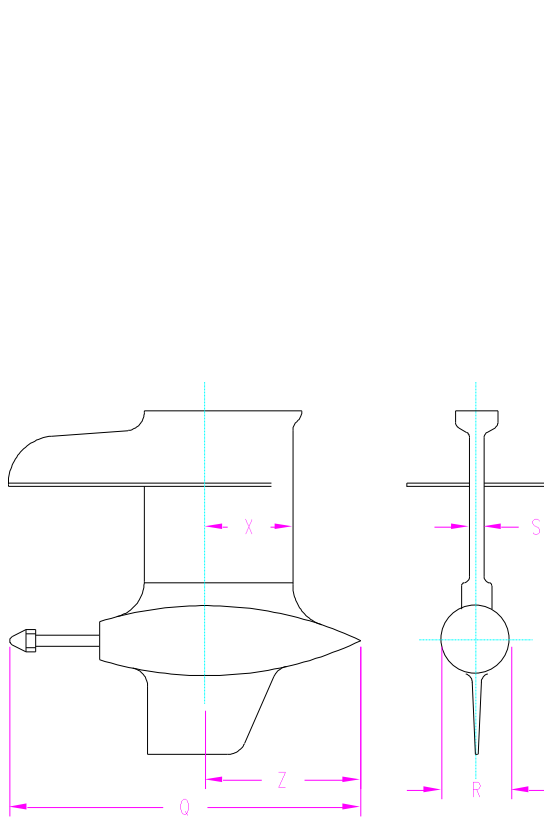

Figure 3. Lower unit

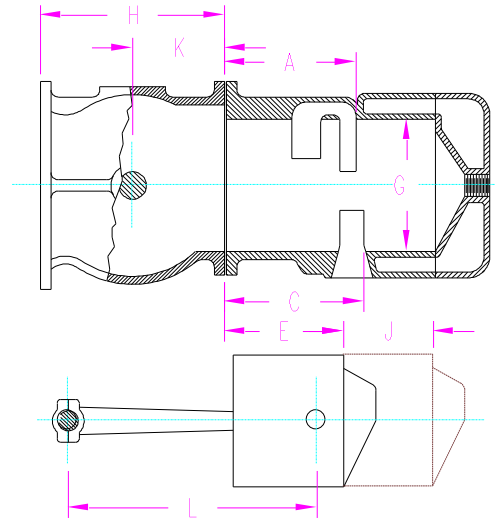

Figure 4. All C Service and C Racing powerheads except Johnson PO

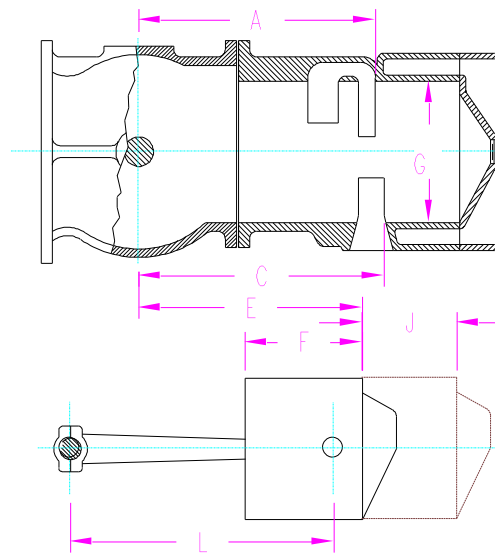

Figure 5. Johnson PO powerhead

## C Service and C Racing Class Boat Rules

Boats utilized within the four C Service and C Racing classes have design restrictions as detailed below:

### Runabouts:

1. Must be a displacement-type hull without steps in the bottom.
2. The bottom may not have any breaks in longitudinal or transverse continuity other than keel or lapstrake. The keel or lapstrake may have no greater depth than 3/4" when measured across the total width of the boat.
3. The design may not make use of external air pressure or tunnel effects.
4. Runabouts may not compete with hydros.
5. 13' runabouts built prior to 1986 which were legal when built may continue. Runabouts built after 1985 must meet the following dimensions. The measurement tolerance is +/- 1/16".
  - A. The minimum length at the centerline.
  - B. The minimum beam at the transom.
  - C. The minimum vertical depth measured at the transom from the deck to the keel.
  - D. The maximum tumblehome at amidships.
  - E. The minimum width of the deck 2' aft of the bow.
  - F. The minimum depth measured 2' aft of the bow.

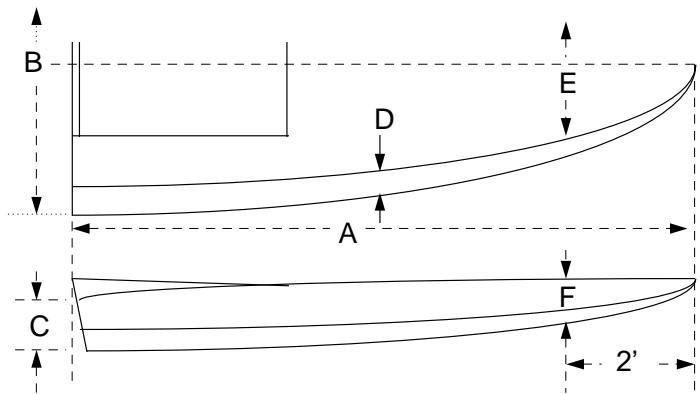

Figure 6. C Service and C Racing class runabout hull dimensions

Dimension	Specification
A	13' minimum
B	48" minimum
C	9" minimum
D	10" maximum
E	11" minimum
F	10" minimum

### Hydros:

Hydros may be of pickle-fork design no matter when the boat was constructed.

## C Service and C Racing Class Motor Rules

### 1. General C Service and C Racing Motor Rules:

- a. Motors may be modified within the specifications listed in the motor specifications. Ports may be squared on the top and bottom. Additional ports are not permitted.
- b. Additional lubricators are permitted.
- c. The OMC Speeditwin may utilize either the Vacturi AO-500 or the original factory carburetor. For all other motors, the Vacturi AO-500 is the only carburetor permitted.
- d. Mufflers may be removed, but tuned exhaust and intake systems are not permitted. Tank brackets similar to those manufactured by Wiseco or Newton are permitted.
- e. Motors must have fuel tanks of approximately the original shape and in approximately the original location and use gravity to flow fuel to the carburetor. The interchange of Johnson and OMC (Evinrude, Elto) tanks is permitted.
- f. Fuel will consist of either methanol and a lubricant or pump gasoline and pleasure use outboard motor oil. The fuel mixture may not contain nitro compounds or oxygen inducing additives.
- g. Only 2-bladed propellers are permitted. Cleaver-shaped propeller blades are not permitted.
- h. Service motors are legal Racing motors, but Racing motors may not run in Service classes.
- i. Ignition systems of any type are permitted. Systems other than the points-condenser-coil system must be hidden under the flywheel to maintain the original appearance.
- j. The lower unit shape and contour may be modified within the limits of the specifications.
- k. All parts manufactured before 1986 which meet the original manufacturer's specifications and which meet the current specifications are approved. All parts manufactured after 1985 which are reproductions of the originals and which meet the current specifications are approved. Any parts manufactured after 1985 which are not reproductions of the originals or which do not meet the current specifications must be approved in advance by the C Service and C Racing Technical Committee.
- l. One cylinder may exceed .050" overbore, provided the total overbore of the two cylinders does not exceed .100".



**2. C Service Motors:**

- a. Service motors must use the original motor manufacturer's crankcase, crankshaft, and cylinders, or replacement parts approved by the C Service and C Racing Technical Committee. The P-50 may utilize the PR-style crankcase, crankshaft, and connecting rods.
- b. Service motors may be modified within the limits of the specifications, except as specified.
- c. Material may not be added to the crankshaft, but crankshafts may be beveled, balanced, and shortened.
- d. Material may not be added to the inside of the crankcase or cylinder block so as to reduce the internal volume.
- e. Modifications are not permitted to the combustion chambers of the OMC Speeditwin, except it is allowed to increase the size of the chamfer around the spark plug hole on Speeditwin cylinders. The Johnson P-50 or PX-50 may only use the original stock P-50 cylinder heads. No changes may be made to the combustion chamber of the original stock P-50 cylinder head.
- f. No change may be made to the placement of the carburetor, nor will any additional intakes be permitted.
- g. Johnson Service motors shall use the original drive shaft housing and clamp bracket assembly or similar after market drive shaft housing with a minimum length of 12 7/8". OMC Service motors may use any drive shaft housing and clamp bracket assembly provided the drive shaft housing is not less than 10" in length (including any spacers).
- h. The interchange of Service motor power heads and lower units of different manufacturers shall not be permitted unless of similar specifications.
- i. Addition of a ball or roller bearing on the lower unit pinion shaft at the top of the pinion case is permitted.
- j. Original crankcase bushings may be replaced with any type of bearing and seal. Material may be added to the crankcase to accommodate bearings and seals provided the internal crankcase volume is unchanged.
- k. The Johnson P-50, PX-50, and PO may use the Johnson S-45 (16hp) stock lower unit provided it meets the specifications. The P-50 / PO is allowed to use the PR-50/55 pinion casting, provided it meets specifications.
- l. The OMC Speeditwin may use the original Evinrude/Elto, Wiseco, Eldredge, Go-Mc, Goslee, or Wagner lower unit.
- m. Additional approved replacement parts for the OMC Speeditwin are:
  - the Ezzo crankcase
  - the Miller crankcase
  - the OMC V4 "100 HP" connecting rod
- n. Additional approved replacement parts for the Johnson P-50/PX-50 are:
  - the PR-style crankcase, crankshaft, and connecting rods
  - the mid-'70's OMC 40HP connecting rod
  - the Williams Delrin connecting rod retainer
  - the Chrysler / Mercury connecting rod (Chrysler FA 335016-2, Mercury 818052-A6)
- o. Additional approved replacement parts for the Johnson PO:
  - the Chrysler / Mercury connecting rod (Chrysler FA 335016-2, Mercury 818052-A6)
  - the mid-'70's OMC 40HP connecting rod
  - the Williams Delrin connecting rod retainer



**3. C Racing Motors:**

- a. Racing motors must use the original drive shaft housing and clamp bracket assembly or similar after market copies.
- b. The interchange of parts between racing motors (Johnson, Evinrude, and Hubbell) is permitted provided they are of similar specifications.
- c. The interchange of Racing C parts manufactured by Hubbell, Vincent, Fuller, Jones, Myers, Harden, Wiseco, and Starnes is permitted provided they are of similar specifications.
- d. In addition, the following are approved replacement parts for use in the Racing classes:
  - the mid-'70's OMC 40HP connecting rod
  - the Williams Delrin connecting rod retainer
  - the Chrysler / Mercury connecting rod (Chrysler FA 335016-2, Mercury 818052-A6)



## Conversion Tables

### Fraction / Decimal Equivalents

Fraction	Decimal	Fraction	Decimal
1/64	.0156	33/64	.5156
1/32	.0313	17/32	.5313
3/64	.0469	35/64	.5469
1/16	.0625	9/16	.5625
5/64	.0781	37/64	.5781
3/32	.0938	19/32	.5938
7/64	.1094	39/64	.6094
1/8	.1250	5/8	.6250
9/64	.1406	41/64	.6406
5/32	.1563	21/32	.6563
11/64	.1719	43/64	.6719
3/16	.1875	11/16	.6875
13/64	.2031	45/64	.7031
7/32	.2188	23/32	.7188
15/64	.2344	47/64	.7344
1/4	.2500	3/4	.7500
17/64	.2656	49/64	.7656
9/32	.2813	25/32	.7813
19/64	.2969	51/64	.7969
5/16	.3125	13/16	.8125
21/64	.3281	53/64	.8281
11/32	.3438	27/32	.8438
23/64	.3594	55/64	.8594
3/8	.3750	7/8	.8750
25/64	.3906	57/64	.8906
13/32	.4063	29/32	.9063
27/64	.4219	59/64	.9219
7/16	.4375	15/16	.9375
29/64	.4531	61/64	.9531
15/32	.4688	31/32	.9688
31/64	.4844	63/64	.9844
1/2	.5000	1	1.0000

### Metric Conversion

For purposes of motor inspection, the following metric conversion factors will apply:

- millimeters / 25.4 = inches
- inches x 25.4 = millimeters
- cubic centimeters / 16.387 = cubic inches
- cubic inches x 16.387 = cubic centimeters

The formulas for calculating motor displacement are:

- $(\text{Bore})^2 \times 0.7854 \times \text{Stroke} \times \text{No. of cyl.} = \text{Cubic Inches}$
- $(\text{Bore})^2 \times 0.7854 \times \text{Stroke} \times \text{No. of cyl.} \times 16.387 = \text{Cubic Centimeters}$