

2015 JUNIOR CLASS RULES

EFFECTIVE 2/16/2015

Junior Hydro, Junior Runabout, AX Hydro, AX Runabout

1. The APBA Junior Classes are developed in order to give young people an alternative activity that will help teach boating safety and sportsmanship relating to the sport of power boat racing. It will furthermore cultivate a curiosity about science, math, reading and writing that will improve young people's learning skills by creating a desire to excel. **The AXH and AXR classes have been developed so that drivers, who meet the minimum age, can gain experience to further their development and graduate to the larger faster classes, there is no age limit.** The goal is to have competitive equipment available to all competitors on an equal basis. It is APBA's desire to promote and support these classes on a national and local level.
2. In order to eliminate any confusion between Junior Class rules, Junior Hydro & Junior Runabout rules and AXH & AXR rules, the following definitions apply.
 1. Rules including the terms Junior Class, Junior Classes, Junior Driver and Junior Boats apply to all four (4) classes under control of the Junior Committee.
 2. Rules including the terms Junior Hydro (also known as JH) and/or Junior Runabout (also known as JR) apply only to those classes.
 3. Rules including the terms AXH and/or AXR apply only to those classes.

SAFETY RULES FOR JUNIOR CLASSES

SAFETY RULE 1 • NEW DRIVERS

New drivers must, for ten (10) races, place a white cross (X) on their helmets, with the stroke of the X to be a minimum of 2 inches wide. The cross must extend from the front tip up over the top of the helmet to the back rim of the helmet, and from the left ear up over the top of helmet to the right ear. A new driver is any APBA member in good standing who has never driven a registered outboard powered boat in closed course competition heat racing. The new driver must be given an oral examination by the referee, assistant referee, or a person designated by the referee or assistant referee. A new Junior driver must also pass an open-book written test, available from the APBA website, before competing. The new driver must show knowledge of course racing rules before being approved to enter a race. Any new driver's first day of participation in competition must consist of at least one (1) heat of racing during a sanctioned event in which the new driver will drive in a position at the rear of the pack and be observed by the Referee and course officials. If the driver is not cleared for "open competition" at the end of that heat, he/she shall run an additional heat in the same manner until cleared by the Referee.

SAFETY RULE 2 • EQUIPMENT

1. All boats must have enough buoyancy, either natural or from use of flotation gear, to float the combined hull and motor.
2. To prevent ingestion of water in the engine, all carburetors shall have a spray shield. Carburetor spray shields are not required for rear-facing carburetors or straightaway time trials. Hull cowlings and canopies may serve as spray shields provided they extend over the carburetor(s). On engines with cowlings, said cowling shall constitute a spray shield.
3. All boats must have an operational steering system. Steering cables must be attached to the steering bar with fully enclosed interlocking hooks; or by use of clevis and bolt, said bolt to be secured with cotter pin or wire. "S" hooks are specifically prohibited. Two cable clamps will be required at both terminations of the steering cable. Springs in the steering are permissible as long as they are looped with steering cable and clamped with two (2) steering line clamps. Steering cable anchors must be bolted to the boat.
4. Any boat's plastic windshield or cowling must have a protective molding on the exposed edge.
5. All boats must have an automatic device to close the throttle when released by the driver. All engines must be equipped with full carburetor butterflies.
6. All Junior boats will have a tether-activated operational ignition cutoff switch (kill switch). When activated, kill switches must cut off the ignition to all cylinders of the engine. The tether switch should be mounted forward of the driver and use a minimum length cord, which at full extension from the switch, must not touch the engine. The tether must be attached to the life jacket or wrist while racing. Taping of either kill switch cap or tether in a manner which interferes with the functional operation of the kill switch is prohibited. In a LeMans start, the tether must be attached before the engine is started.
7. Drivers must wear closed footwear, life jackets, helmets, eye protection and cut-resistant, wrist-length sleeves and cut-resistant, ankle-length pants at all times while on the water for the purpose of driving racing equipment. In closed course racing, when stopped on the course, the driver's helmet only may be removed when no other racing craft are underway anywhere on the course or when the driver's boat is tethered to a towboat. All drivers in Junior Classes must wear impact/flak material incorporated into the life jacket. The impact/flak material will provide full coverage of the front and back of the torso. The intent is to provide impact/flak coverage of vital internal organs. The referee or inspector has the power to prohibit the use of any helmet or life jacket that he/she determines to be potentially unsafe.
8. Each boat must be equipped with a device enabling it to be towed, such as a bow handle or screw eye capable of handling a rope.
9. If corrective lenses are required for a person to drive a motorized vehicle, they will also be required while operating a race boat.
10. A permanently fixed fin or fins may be used on the hull. No Junior Class boats may have a fin or mounting hardware that protrudes beyond the maximum beam of the boat.
11. Hulls used in Junior Classes may not utilize the following:
 - A. hull surfaces that are adjustable while underway
 - B. fins that are adjustable while underway
 - C. water brakes
 - D. trim that is adjustable while underway (power trim)

12. Engines must remain firmly clamped and/or bolted to the transom at all times.
13. It is recommended that gearcases be maintained and contoured, if necessary, within class technical specifications. Gouges, breaks and hollows should be sanded or filled.
14. On the OMC J motors, safety wire must be in place on the steering bar-powerhead bolts. Drivers will be warned once before being disqualified.
15. The driver must be able to exit the cockpit without moving or removing any windshields, canopies or cockpit cowlings.
16. An annual technical inspection of all boats is required prior to competition. A sticker shall be affixed to any boat that meets all safety requirements. Such approval expires each October 31.
17. Junior Classes Hydroplane Pickleforks and Cockpit Noses (ALL HYDROPLANES MUST COMPLY)
 - A. The foremost points of the pickleforks shall have a minimum radius of 1" in one view. This minimum radius shall extend at least 45 degrees to both sides of the foremost point. At one termination point, the thickness must remain at $\frac{3}{4}$ ", at the other the thickness must remain at $\frac{1}{2}$ ". (SEE DIAGRAM)
 - B. All Junior Classes hydroplane hulls built where the cockpit nose extends forward of the body of the hull, shall have a cockpit nose that conforms to the same requirements for shape as the picklefork foremost points described in paragraph A above.

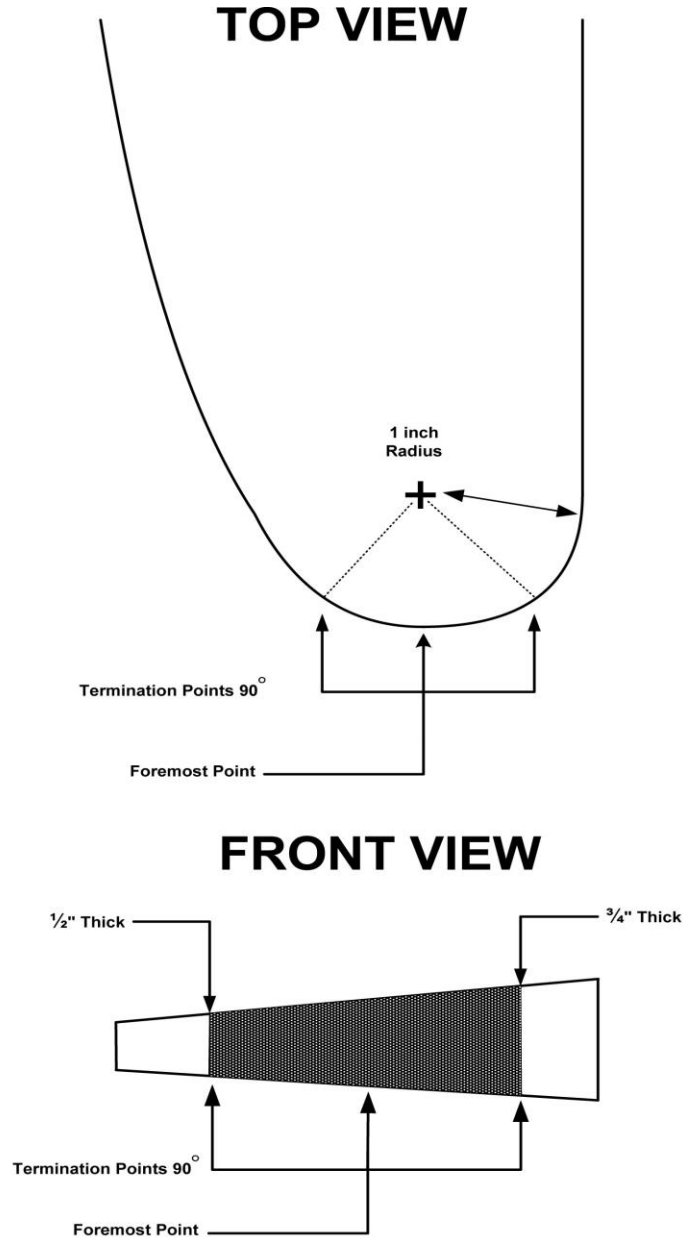

SAFETY RULE 3 • ENGINE MOUNTING HEIGHTS

1. Junior Classes have limitations on where the engine's propshaft may be mounted. The distance between the center of the propshaft at its aft end, and the planing surface, must be no less than 1-3/4" for Junior Hydro and Junior Runabout; and 1 3/8" for AX Hydro and AX Runabout. The planing surface shall be flat (with a tolerance of 1/16 inch for inspection purposes) transversely between the air traps and forward for 18".
2. In JH and AXH, the difference between the propshaft location, as measured at the aft end of the propshaft, and the foremost end of the gearcase and the planing surface, as measured at the split line of the gearcase, shall not exceed 1/2".
3. The measurement of the engine height shall be "as raced" with the engine turned straight (propshaft in-line with the fore-aft centerline of the boat).
4. This rule applies to boats running in straightaway Trials.

SAFETY RULE 4 • OPERATION

1. Locked throttles are prohibited in competition. While getting on plane, drivers must keep one hand on the throttle and one foot in the cockpit. No driver may assume a driving position which requires that he/she remove his/her hand from the throttle. A foot throttle may be used in lieu of a hand throttle, but it must be operated in the manner described for hand throttles. While racing, one knee must remain below the top of the cockpit at all times, unless the driver is in a sitting position. While racing, standing in the boat or sitting on or straddling the engine are specifically prohibited. The final decision regarding driving safety will be made by the Referee and Race Committee.

2. No motor shall be started when affixed with a propeller, nut, washer or pin — any part of which is out of the water — unless it is hand-held over the water prior to a launch. Boat stands are permitted for this function only if they are specifically designed as launching stands. For the purpose of testing or warming up, motors with propellers affixed may be started under the following conditions: The boat must be on a secure stand or dolly with the bow pointing directly towards shore, and adequate warning must be given to participants nearby prior to startup. Engines required to use gasoline as fuel must have at least half of the propeller in the water. Violation of this rule will result in the driver's disqualification for the remainder of the day from the class in which the infraction occurred. This prohibition shall not apply during the five minutes immediately preceding the start of a race using a "jetty" or "modified LeMans" start.

3. OVERLAP: When there is less than one boat length of open water between a leading boat and a following boat, an overlap is established. In a position of overlap, the following rules shall apply:

- A. The front boat shall not alter its course across or into the established path of the rear boat.
 - B. The outside boat must give the inside boat room to clear any course marker.
 - C. Any violation of the overlap rules listed above will result in the disqualification of the offending driver for the heat.
4. Drivers shall not drag feet, legs, hands, or arms through the water to aid in turning.
 5. The chief referee or assistant referee must meet with turn judges to instruct them of flag and safety procedures.
 6. No driver shall leave the pits after the one-minute signal has been given. Violation of this rule will result in a disqualification for the day from the class in which the infraction occurred.
 7. Any driver who is off plane at the start of the race or during the race and pursues a position on the race course in an unsafe manner shall be disqualified for the heat.

SAFETY RULE 5 • TESTING

1. Junior Hydro and Junior Runabout drivers must be given separate testing time, aside from all other classes.

SAFETY RULE 6 • ACCIDENTS/FLIPS

1. A blue and white or blue and yellow flag shall warn drivers of a flipped boat or other obstructions on the race course. Blue and white or blue and yellow flags will be displayed from the judges stand and patrol boats.
2. Turn judges, race committee, referees or assistant referees have the authority to stop a heat. If the lead boat is on the final lap, the order of finish shall be determined by the order of finish of the previous lap. The driver or drivers responsible for the stoppage of the heat will not be scored.
3. The heat must be stopped if a Junior Hydro or Junior Runabout driver goes into the water prior to the final lap of any heat. During the final lap of a heat, the heat shall be stopped if a Junior Hydro or Junior Runabout driver goes into the water unless the driver is clearly out of danger.
4. It is recommended that the referee or inspector require any boat that has flipped or was involved in an accident be re-inspected for safety before further competition in that boat.

SAFETY RULE 7 • COURSES

1. The race course shall be marked with soft buoys that do not damage, deflect or upset boats.
2. In laying out courses, race committees are urged to take into consideration the safety of the contestants with regard to obstacles, traffic and other dangers. It is recommended that the distance from the starting line to the entrance buoy of the first turn be at least 1000 feet where possible.

SAFETY RULE 8 • AGE REQUIREMENTS

1. Junior Hydro and Junior Runabout drivers must be at least nine years of age, determined by birthdate. Drivers may not compete in Junior Hydro and Runabout classes after the end of the racing season in which they turn 16 years of age. AXH and AXR drivers must be at least 12 years of age.

RACING RULES FOR JUNIOR CLASSES

RULE 1 • GENERAL

1. Only a regular member club of the APBA may conduct APBA races.
2. In order to be eligible to compete in the races sanctioned by the APBA an individual must:
 - A. Be a racing member in good standing of the APBA.

- B. Be a member in good standing of a member club of the APBA. (Participants in special events are exempt from this requirement.)
 - C. Register with the APBA National Headquarters for the class or category in which they intend to compete.
 - D. Show their current APBA membership card and club membership card (if required) to the local registration official when filing their entry or checking in at a regatta. Regardless of the class entered, the motor manufacturer, piston displacement and the class entered must be clearly specified on the entry blank filed at the regatta.
 - E. Display an official racing number and meet all technical requirements of the class entered.
3. Junior Classes racing shall be governed by the By-Laws of APBA. All rule changes shall be governed by By-Law Article XII, Section 12.7.
4. Subject to the provisions of the by-laws of this association, Junior Classes racing shall be conducted under the supervision of the Junior Classes Committee. Except as noted in Rule 14 below, and subject to the by-laws of this association, the decisions of the Junior Classes Committee shall be final in all matters pertaining to the administration and interpretation of the Junior Classes rules.
5. The Junior Classes Committee shall have the power to review any and all paperwork resulting from its races and time trials and shall have the power to correct any errors up to 90 days after the event.
6. At the sponsor's request, Junior drivers shall wear uniforms consisting of a minimum of long pants and shirts with racing identification. Such a request must appear on the race circular.
7. Junior drivers may not utilize radio communication with the following exception: "New" drivers in these classes (see Rule 1 for definition of "new") may utilize radio communication at non-championship and non-record races.
8. Participants in Junior Hydro and Junior Runabout may receive outside assistance prior to the completion of a heat.

RULE 2 • REGATTAS

1. The Referee and Inspector must be chosen from the lists of Referees and Inspectors, approved by the appropriate category chair and region chair.
2. In the event a driver cannot attend a Drivers' Meeting because of extenuating circumstances, it shall be the privilege of the Referee to permit the driver to be excused. Any driver who answers for an absent driver at the drivers' meeting shall be disqualified for the day.
3. In the Junior Classes, the same boat and motor must be used in all heats of a race where points of a heat are counted in the final standings. It shall be legal to change engines between elimination heat and/or final heats only if there is irreparable damage to the engine. However, the contestant must notify the Inspector, make proper notification and registration prior to the finals at the registration stand, and present both engines to the Inspector for inspection immediately following the final heat. It shall not be legal to change boats between elimination heats and/or final heats unless the boat is deemed damaged and unsafe by the Inspector or Referee. Drivers in different qualifying races or heats may not use the equipment previously used in qualifying for the same event.
4. At least one qualified turn judge approved by the Referee shall be required in each turn. All turn judges should be APBA members. The Referee will review the proper interpretation of the overlap rule prior to the start of the race. All overlap violations will be called by the turn judges and/or Referee. All disqualifications will be carefully reviewed by the Referee.
5. Boats shall race without handicap or time allowance, unless the race specifically is designated as a handicap race. No record made in a handicap race may be claimed as an official record.
6. Special races run under restrictions other than those embodied in these rules may be included in the program when announced as such in the race circular, but no official record shall be allowed for speeds in such races. Marathon races for Junior Runabout shall be counted as special races.
7. The race for each class shall consist of up to three (3) heats. The maximum number of boats competing in any heat shall be determined by the Referee after consulting with the racing Commissioners present. In Junior Classes, the maximum number of boats allowed to participate in any closed course heat shall not exceed twelve (12); this twelve (12) boat maximum does not apply to marathon races. Due consideration shall be given to safety at the particular course. The maximum number of boats need not be the same for every class.
8. If the total number of entries exceeds the number determined to be safe for the race, this number shall be separated into elimination heats by drawing lots. Secondary qualifying heat(s) may be run for all those entrants not previously qualified to fill the field to its announced maximum. In the event a secondary qualifying heat is run, no points will be awarded for the secondary qualifying heat. When elimination heats do not result in a full field for the final heat, the race committee shall fill the field by selecting additional boats in the following sequence:
- A. Boats which finished an elimination heat but not high enough to qualify, in order of least recorded time.
 - B. All other boats that were entered in the race except those previously disqualified from the class.
 - C. If the boats in the last group (B) overflow the field, the exact number is to be selected by lot.
9. The local Race Committee may run one-heat races provided that notice has been given to drivers on the race circular. If circumstances beyond the control of the Race Committee develop, they may also run a one-heat race. This rule does not apply at the Nationals where the appropriate category chair must give approval.
10. Each heat shall be a maximum of approximately five (5) miles and shall be a minimum of three (3) laps. However, the Referee is empowered to reduce the number of laps if, in his/her judgment, such action would be in the best interests of the race sponsor and the drivers.
11. It is permissible for the race committee to schedule and run two races for any class or classes it chooses on any single day so long as the same is published on the circular. However, if the race committee determines that inclement weather or other circumstances warrant, the second race may be cancelled by the race committee.
12. AX Runabout Marathons
- A. The race may consist of one or two heats. If the race consists of two heats, they shall be on successive days and the winner in each class shall be determined on the basis of total points scored in the two heats.
 - B. Classes may be run separately or together at the discretion of the race committee. They shall be scored separately and must consist of three (3) bona fide starters or more per class to qualify for national points.
 - C. Each heat shall not be less than 20 minutes or 15 miles in length from start to finish.
 - D. Either Jetty (modified LeMans) or clock starts will be accepted.
 - E. Regular points will be awarded to the winners of the overall race.

- F. If the race consists of two (2) heats, there will be no change of equipment between heats unless equipment is damaged beyond repair. If equipment is changed but not damaged, points for the first heat shall not be counted in the overall standings.
- G. The race may be point-to-point form or a closed course of any size.
- H. No claims for records will be entertained.
- I. In lap marathons, any entry sinking or damaging a buoy will be penalized one lap.
- J. In lap marathons, any entry jumping the gun will be penalized one lap. In the event of a restart, any entry jumping the gun will be penalized one lap. In general, each entry shall be penalized one lap of each gun jump.
- K. In the event a boat starts the heat but does not finish it, that boat shall be scored in the next available position behind all other boats which have finished the heat. In the event multiple boats start the heat but do not finish it, those boats not finishing shall place according to last completed lap finished under power. In the event that multiple boats drop out on the same lap, each boat will receive the average of the sum of the tied positions. This rule only pertains to closed course lap marathons where the entire course is visible from the judge's stand

RULE 3 • RECORDS

Records in Junior Classes shall be awarded as follows.

1. Competition records of five (5) miles shall be established on surveyed courses laid out in laps measuring one and one quarter (1-1/4), or one and two thirds (1-2/3) miles and recorded separately.
2. Three (3) mile records shall be established on a 3/4-mile course, 4 laps. The 3/4-mile course will be required to use the layout supplied by APBA National Headquarters. Junior Classes may also establish competition records of three (3) miles on a surveyed course of one (1) mile per lap and recorded separately.
3. With the exception of straightaway records, in order for a driver to qualify for a record, there must be a minimum of four (4) bona fide starters in the heat. For Junior Classes there shall be no requirements on the number of finishers in the heat or the timing of the finish of any boat in the heat relative to another boat in the heat.
4. For Junior Classes, straightaway records shall be set over a one (1) kilometer or 1/4 mile course.
5. There shall be no records for lap speeds.
6. If two records are established in the same class within a four-day period, the fastest record will be approved, regardless of the time difference between the two records.
7. Upon request, the Junior Classes Committee will sanction and supervise time trials for any UIM racing class or classes. In such case, UIM rules will apply.
8. The highest speed attained in a class at each event which equals or betters the previous record speed multiplied by 1.003 shall qualify a driver for a record, provided the driver and the equipment meet all other requirements for that class.
9. Any competition records in the Junior Classes must be set using a clock start.
10. All records established in JH and JR prior to the 2005 racing season shall be frozen and new records will be established.

RULE 4 • START & FINISH

1. At all races a preparatory signal shall be given three (3) minutes before the start of the heat and, at this time, at the judges stand, a green flag will be displayed. The race committee may extend the period prior to the start of the heat to four or five minutes for some or all classes if local conditions warrant. Additionally, at non-championship races and Divisional Championship Races a "short" three-minute period (less than three minutes) may be used when announced at Drivers Meeting and all boats entered in that heat are on the course, planed off and in the milling area.
2. There shall only be one (1) start per heat. Boats crossing the starting line during the last thirty (30) seconds before the start shall be disqualified; this time period may be shortened by the referee when local conditions warrant. Any boat passing the 500' marker during the last fifteen (15) seconds before the start is committed to the start and must maintain a straight line; this time period may be shortened by the referee when local conditions warrant.
3. The start shall be final, even if there is only one (1) legal starter. In the event there is no legal starter, the heat shall be cancelled.
4. With the exception of divisional and national championship closed course regattas, "Jetty" or "modified LeMans" starts are permitted if so specified on the race circular. The contestants participating in a jetty start will be assigned starting positions by lottery. Prior to the start signal, all engines will be stopped and the boat attended by no more than three crewmembers. A preparatory starting signal will be given. A member of the race committee will start the race by waving a flag. Either a crewmember or driver may start the engine. If the engine does not start on the first attempt, the crewmembers may receive additional assistance.
5. With the exception of closed course divisional and national championships, "flag" starts are permitted if so specified on the race circular.
6. A heat may be cancelled if fewer than three (3) boats cross the starting line except when a previous heat in the race has been run. However, if the first heat of a race is started with at least three (3) bona fide starters, a rerun of that heat must be run if there is at least one (1) bona fide starter. If a previous heat for the class has been run, any subsequent heat shall be cancelled only if no bona fide starters cross the starting line or if all boats cross the starting line before the gun.
7. A legally started heat cannot be cancelled. In the event that a stoppage of a heat is necessary and the lead boat is on the final lap, the order of finish shall be determined by the order of the previous lap. The driver or drivers responsible for the stoppage of the heat will not be scored. If the lead boat is not on the final lap, the heat must be restarted and cannot be cancelled unless there are no legal starters.
8. The referee may call for the restart of a heat under the following circumstances:
 - A. if officials or their equipment have performed in error,
 - B. if officials have failed to record those boats jumping the gun, or
 - C. due to the stoppage of the heat caused by an accident or other on-the-course issue. Should a restart be required due to a stoppage, all boats that are responsible for the stoppage of the original heat, or any restart of the heat, may not participate in any restart. All other drivers entered in the original heat, including gun jumpers, may participate in any restart. In Junior Classes, drivers who committed a driving infraction (other than jumping the gun) may not participate in any restart.

This rule is in effect from the time boats entered in the original heat leave the pits until a winner is established.

9. All races shall have a photographic start. In the event that a snapshot is taken, all races must have at least one camera electronically synchronized with the starting clock. In the event that a video camera is used, the video must record the moment when the starting clock reaches zero (0). The camera shall be aligned with the starting line markers as the drivers' reference point exists. If the markers shift, the camera should be trained upon the point actually used by the drivers to determine the location of the starting line. Use of the camera is purely an "aid" to those who "call" the start. Upon request, pictures of the start are required to be shown to the drivers' representative. In the event of a camera or film failure, the Referee will, with the assistance of the Race Committee, render the necessary decision.

RULE 5 • COURSES

1. It is recommended that there be a minimum of four turn markers in each turn.
2. Floats used for finding anchors or ropes are not racing markers.
3. The driver of a boat that damages or dislodges a buoy, causing damage that requires race-delaying attention by the race committee, shall be disqualified for that heat.
4. The starting line must be marked with two (2) buoys. One of these starting buoys serves as an inside course marker; the other serves as the outside course marker.
5. When not otherwise specified, all marks shall be passed on the driver's left-hand side. Any contestant who fails to turn a mark may validly continue in the heat, provided the contestant returns to the mark and passes it in the proper manner and then continues his course. Running an extra lap shall not constitute a fair turn.

RULE 6 • RACING NUMBERS

Each racing member owning a boat or boats shall annually request National Headquarters to assign him/her a racing number for each category raced. This number, or numbers, shall be valid for the current membership year. The racing member will use these numbers on all boats of all classes which he or she may enter in given category's races. The racing number shall consist of a letter designating the geographic section of the country where the owner resides and an assigned number. The assigned number shall range from 1 to 999. The official racing number must be displayed on both sides of the boat in accordance with the following procedures:

1. Hydroplanes and runabouts shall be affixed with vertical numbers on both sides of the boat. Numbers must be a minimum of six (6) inches in height and one (1) inch stroke where space permits, and shall be black on white or white on black. The background must be solid. There shall be at least one (1) inch background border around each number and letter, where space permits. There shall be a minimum of one (1) inch spacing between each number and letter, where space permits.
2. In addition to vertical numbers and letters, it is recommended that hydroplanes have deck numbers and letters. These deck numbers should be placed on a solid background that contrasts strongly with the color used for the deck numbers.
3. The numbers must be so displayed as to be clearly visible at all times, and shall be securely attached in such a manner that they will not be lost or defaced during a race. The race committee shall have the power to warn, or disqualify without previous notice, any driver who races with improper or illegible numbers.
6. A temporary number, such as an "X" or "I", may be used. However, only one (1) regatta will be allowed without a regular number properly displayed on the hull.
7. In the event one owner enters two boats, both of which carry his/her assigned racing number in the same race, it shall be the owner's responsibility to affix a temporary identifying mark to his/her second entry to assist the scorers in identifying the drivers. The identifying mark shall be in the form of the letter "I" following the official racing number. If the owner enters three boats in the same race, the third entry shall have two such identifying marks following the official racing number, and so forth. Such temporary marks are for the use of the local headquarters or race committee and have no official standing at National Headquarters.
8. With the exception of the temporary numbers mentioned above, and CBF members using a CBF number, no one will be allowed to compete in a regatta without a letter designation and number displayed on the hull.

9. The following letters indicate the residence of Junior Classes boat owners. The letter is to be on the right of the number.

- | | |
|--|---|
| A. Maine, New Hampshire, Vermont | M. Michigan |
| B. Massachusetts | N. New York |
| C. California, Nevada, Arizona, Hawaii | P. Pennsylvania |
| CE. Eastern Canada: Ontario, Quebec and Maritime Provinces | Q. Delaware |
| CP. Central Canada: Alberta, Saskatchewan, Manitoba | R. Oregon, Washington, Idaho |
| CW. Western Canada: British Columbia | S. Ohio |
| D. Connecticut, Rhode Island | T. Oklahoma, Texas, New Mexico |
| E. Virginia, West Virginia, Maryland, District of Columbia | U. North Dakota, Wyoming, Montana, Colorado, Utah |
| F. Florida, Georgia, Alabama | V. Illinois |
| G. Minnesota, South Dakota | W. Wisconsin |
| H. Indiana | X. Iowa, Nebraska |
| J. New Jersey | Y. Kansas, Missouri |
| K. Kentucky, Tennessee | Z. North Carolina, South Carolina |
| L. Louisiana, Mississippi, Arkansas | |

Boat numbers with the letter "O" are no longer assigned.

RULE 7 • BOAT NAMES AND ADVERTISING

The APBA reserves the right to review boat names and advertising displayed on members' boats, and the Executive Director may at his/her discretion refuse to issue boat numbers to any applicant if, in the Executive Director's estimation, a boat carries advertising or a name which is obscene or might be of such a nature as to cause embarrassment and cast any discredit on the sport of powerboat racing. A Race Committee may refuse entry to any contestant who violates the letter or spirit of this rule.

RULE 8 • MEASUREMENT AND INSPECTION

1. Motors, hulls and other equipment subject to these rules shall be inspected by the Inspector, and a report of any violation of rules and regulations submitted at the earliest possible moment to the Race Committee for action. Except as noted below, it shall be up to the discretion of the Motor Inspector, under the direction of the Referee, as to the extent of the inspection conducted.

2. Racing equipment shall be available for examination previous to the race and if found not in compliance with any governing rule or regulation, unsafe, unseaworthy, or unmanageable, or if the owner or driver has failed to live up to the spirit or letter of the rules, the Race Committee may rescind the entry. Correction or substitution may be permitted if made previous to competing in the race, but the start shall not be delayed to allow compliance. Dismantling of motors before racing shall not be required.

3. The Inspector shall have the power after the finish of any race to order any contestant to dismantle his or her motor for inspection and measurement.

4. Each winning motor and each record-claiming motor and such others as may be designated by the Race Committee shall be inspected. With the exception of Divisional and National Championship regattas, or at regattas where a special inspector has been assigned by the appropriate commission, the Referee or Inspector may waive inspection of any motor as long as no APBA or UIM records are at stake. Motors used to set records or win national championships in Junior Classes shall be disassembled and completely inspected by the official inspector.

5. The driver shall be responsible for the condition of the motor and hull as raced. Errors on the part of the manufacturer, boat builder, mechanic, or previous owner shall not excuse non-compliance with the rules.

6. For the purpose of national high points, equipment disqualifications will be scored as one race with zero points.

7. Upon refusal of inspection procedures at any regatta, said driver will be disqualified. Upon refusal of inspection procedures at Divisional, National or record-attempt regattas, said driver shall be suspended for a period of one year for unsportsmanlike conduct.

RULE 9 • ILLEGAL EQUIPMENT

Any driver who races a motor or hull that does not meet with specifications as quoted in these rules, will be disqualified and warned. With the exception of disqualifications for fuel, engine height or minimum racing weight, a second disqualification for the same offense in the same class within a six (6) month period will result in the automatic suspension of the driver for one (1) year from the date of the second disqualification.

Note: Violations of a non-speed-advantage nature are covered in General Racing Rule 18.

RULE 10 • PRIZES

1. Prizes shall be awarded in accordance with place of finish.

2. APBA points and prizes shall be awarded to the driver. The driver may, at his/her option, instruct the Race Committee to award the prize to the owner of the boat or motor.

3. If a contestant is disqualified, prizes shall be awarded to the next contestant on the basis of points awarded to the legal boats in the corrected order of finish.

4. The local Race Committee may divide prize money on the basis of the individual heats, instead of on the basis of the entire race, when so specified in the regatta circular.

Notes:

A. The listing of prizes on the circular, and return of prizes, are covered in the APBA General Racing Rules.

B. This rule would not prevent the payment of expense money.

RULE 11 • JUNIOR CLASSES PROPELLERS

1. All Junior Hydro and Junior Runabout participants, except those using 60-J Mercury motors, must use APBA Junior Classes propellers to participate in championship events or earn National High Points.

2. The APBA Junior Classes will have a set of 24 that will be used solely at National and North American Championship races. These propellers are designated as "Junior Championship Propellers." The Junior Championship Propellers must be run for all qualifying and final heats at National and North American Championship races. The Junior Championship Propellers will be verified annually, prior to the Junior Championship Propeller events, to have a top speed within a range of 0.6 (six-tenths) of each other as measured with a GPS max speed. A member of the Junior Classes Committee must be present during the annual Junior Championship Propeller verification process. Junior Championship Propellers will be engraved with "Junior Championship" and will have a blue ceramic coating. It is the responsibility of the conducting club to return the Junior Championship Propellers to the APBA National Headquarters within one week of the finish of each championship event.

3. The APBA Junior Classes propellers will be distributed in a manner which is at the discretion of the conducting club. At National, North American and Divisional Championships, as well as events where APBA Records are at stake, the following procedure will be used.

A. All props will be cleaned and numbered for distribution by a blind draw prior to the first heat of racing.

B. Each driver will submit their APBA Membership Card for the race committee to hold before they draw for propeller(s). The card will be held until the propeller is returned at the conclusion of racing and the entry clears initial inspection.

C. Prop Selection:

i. For the Nationals and North American Championships, each driver will be issued one Junior Championship Propeller for each heat of racing. No exchanges will be accepted.

ii. For the divisionals and events where APBA records are at stake, each driver may select up to two (2) props regardless of the number of classes they are registered for, and may exchange only one of those props if they choose to. Each driver will only be allowed one opportunity to exchange a prop.

iii. The number on the propeller(s) assigned to each driver will be recorded on a checkout list.

D. Junior Propellers, including Junior Championship Propellers, must be removed from the prop shaft in the presence of the inspector or designee and redistributed after each qualifying and final heat. Drivers running props other than the ones issued to that driver on the checkout list will be disqualified.

- E. Prop drawings will be done for each day of racing. If elimination races are necessary, there will be separate prop drawings for elimination races and for finals.
 - F. At the end of the elimination races, or end of the day of racing, all props will be turned back in before boats are released from the inspection area. The props will be cleaned, renumbered, and reassigned for the next day of racing or for Finals. Once propellers are returned, the driver will receive his/her APBA card back.
4. No Junior Hydro or Junior Runabout records shall be recognized unless they are set with the APBA Junior Class propellers provided by APBA.
 5. Any participant with the exception of race official who alters or marks on the propellers in order to later identify them will be fined double the current cost of a new propeller.

RULE 12 • INQUIRY

An inquiry is a communication to the officials from a driver requesting information, clarification of a decision, or interpretation of an occurrence on the race course. An inquiry must be made in writing to the designated drivers' representative and forwarded to the proper official for a timely answer. A fee will not be charged and it will be the responsibility of the inquiring driver to contact the drivers' representative for the race official's answer.

RULE 13 • PROTEST

A protest is a written statement by a driver or owner to the Race Committee alleging violation of the rules affecting their particular class.

1. Any Junior driver may protest a violation of the rules by filing a written statement of the protest (setting forth specifically the rule or matter that is being protested) with the referee or assistant referee, along with a one hundred dollar (\$100.00) filing fee.
2. Protests involving the sanction or the manner in which the regatta is being conducted must be made within sufficient time to allow the alleged violation to be corrected. The Race Committee shall consider the protest and render a decision.
3. Protests involving the eligibility or legality of an entry must be filed in writing with the referee or assistant referee not later than one hour after the finish of the inspection in question, or one hour after the finish of the final heat of the day, whichever is later. Any driver wishing to file a protest after the final heat of the day has been completed must notify the referee or assistant referee of his or her intent to file a protest within fifteen (15) minutes of the time when the final class of the day clears inspection. The notification of intent to file a protest may be either written or verbal.
4. If a technical violation is alleged, the Inspector shall conduct an inspection of the equipment that is the subject of the protest and shall make a report to the Race Committee. The Race Committee shall consider the protest and render a decision. In such a case the Inspector shall be disqualified from voting on the ultimate question.
 - A. The owner of protested equipment must present the protested equipment to the inspector immediately upon request of the Referee. Failure to present protested equipment shall result in disqualification.
 - B. The inspector may impound components to determine their compliance with the rules.
 - C. When a protest of equipment is lodged at a non-championship regatta and facilities (or equipment) are inadequate for complete engine disassembly and inspection, the protested components may be taken into custody by the referee or a person designated by the referee for insured shipment to the nearest qualified inspector for evaluation. The cost of the shipment, inspection, and reassembly (if requested) shall be borne by the loser.
5. No member of the race committee shall take part in any decision in which they have a direct interest.
6. Any party to the protest may appeal an adverse ruling under this rule pursuant to Rule 14 (below).

RULE 14 • APPEAL

An appeal is a request by a driver or owner to the Junior Class Committee, or Junior Class Appeals Jury asking that a disqualification, or a decision that affects a driver, be reversed or changed. An appeal is a written statement that should be as detailed as possible. Written statements from witnesses may be attached to an appeal.

1. An appeal is made by filing a written statement with the Referee or assistant referee along with the appropriate filing fee. The appeal fee in the Junior Classes will be \$50.00.
2. Appeals must be in writing and filed within one hour of the adverse decision of the Race Committee or Referee, or one hour after the finish of the final heat of the day, whichever comes later. Any driver wishing to file an appeal after the final heat of the day has been completed must notify the referee or assistant referee of his or her intent to appeal within fifteen (15) minutes of the time when the final class of the day clears inspection. The notification of intent to appeal may be either written or verbal.
3. When an appeal is filed by a Junior participant at races other than National Championship events, the matter will be settled by the APBA Junior Class Committee. When the appeal is filed by a Junior participant at National Championship events, the matter will be settled by an appeals committee. The appeals committee at National Championship events will consist of all the members of the Junior Class Committee present. In the event that fewer than three (3) members of the Junior Class Committee are present at the National Championships, the chair of the appeals committee shall appoint additional members to the appeals committee. The chair of the appeals committee will be the Chair, or Vice Chair if the chair is not present, of the Junior Class Committee. In the event that the Junior Class Committee has co-chairs, one of the co-chairs will be the chair of the appeals committee; the other co-chair shall be a member of the appeals committee with no special rights.
4. No member of a commission, the Junior Class Committee, or a Junior Class Appeals Jury shall take part in a decision in which he/she has a direct interest.
5. If a technical violation is alleged, the Inspector shall conduct an inspection of the equipment that is the subject of the appeal and shall present a report to the appropriate decision-making body.
6. A copy of all appeals shall be sent by the referee immediately to the Chair of the Junior Class Committee. Ten days will be allowed for postmark of evidence and testimony mailed to the Committee from all parties concerned.
7. A driver who appeals a suspension may continue to race until the appeal is decided upon by the appropriate decision-making body.
8. Decisions of the Junior Class Committee or Junior Class Appeals Jury shall be based on the rules set forth for the APBA. However, because no set of rules can cover all contingencies, the decision-making body shall be guided by its own judgment of fair racing. In rendering such judgment, the

decision-making body may avail itself of counsel from the referee. Subject to the provisions of the Bylaws of this association, all decisions of the APBA Junior Class Committee or Junior Class Appeal Jury shall be final.

RULE 15 • HIGH POINTS

1. For all sanctioned Junior Class regattas, National Headquarters will tabulate points on a race basis to all drivers competing in sanctioned regattas as follows:

<i>Order of finish</i>	<i>Regular/ Regional</i>	<i>North American Championships/Divisionals</i>	<i>National Championships/World Championships*</i>
First	400.....	800.....	1200
Second	300.....	600.....	900
Third	225.....	450.....	675
Fourth	169.....	338.....	506
Fifth	127.....	253.....	380
Sixth	95.....	190.....	285
Seventh.....	71.....	142.....	214
Eighth.....	53.....	107.....	160
Ninth.....	40.....	80.....	120
Tenth.....	30.....	60.....	90
Eleventh.....	23.....	45.....	68
Twelfth.....	17.....	34.....	51
Thirteenth.....	13.....	25.....	38
Fourteenth.....	10.....	19.....	29
Fifteenth.....	7.....	14.....	21
Sixteenth.....	5.....	11.....	16
Seventeenth.....	4.....	8.....	12
Eighteenth.....	3.....	6.....	9
Nineteenth.....	2.....	5.....	7
Twentieth.....	2.....	3.....	5

Scoring shall be counted down to the 20th position in each class.

*** Bonus Points for World Champions only awarded if World Championships are held in the United States.**

2. All boats crossing the starting line in any heat of the race will be scored nationally as having competed. Boats not scoring any overall points will be credited nationally as having competed with zero points. Races will be scored in accordance with General Racing Rule 21.

3. The High Point Championship is awarded for the best 15 races-defined as the 15 races with the highest number of points scored.

4. There must be three legal boats for a race to qualify for national points at any race. At national championship events there must be at least eight boats for the drivers to earn bonus points.

5. In the event two or more boats have scored the same number of points and also have identical elapsed time for both heats, the match will be awarded on the basis of the fastest individual heat.

6. The Junior driver(s) winning the APBA National High Point Championship in each class shall be awarded the 2-US number.

7. The No. 1, followed by the letter designating the state, shall be given to the driver residing in each state or geographical section who accumulates the most points in either Junior Hydro or AX Hydro; and to the driver in each state/section who accumulates the most points in either Junior Runabout or AX Runabout.

8. Points scored in marathon events shall not be counted toward the high point championships.

9. Separate points for marathon racing will be tabulated on a national basis by National Headquarters. The driver earning the greatest number of points on a national basis in AX Runabout Class will be awarded the "US" shield omitting the number. The points shall be totaled from November 1st through the following October 31st. For final tabulation, and to receive the "US" shield, a driver must have competed in a minimum of three (3) sanctioned marathons in the class for which the points are being tabulated.

RULE 16 • FUEL

1. Only motor fuel compounded of gasoline, and petroleum oil and/or synthetic oil, shall be used.

2. Additives which produce power in excess of that produced by standard pump gasoline and petroleum base oils shall not be permitted. The list of illegal additives includes, but is not limited to, alcohols, nitrates, and other oxygen bearing compounds. Gasohol is not a legal fuel. The baseline for determining legal fuel will be a zero reading on a Digatron meter or equivalent as defined by the Stock Outboard Inspection Manual. At each regatta the inspector may purchase a sample of local gasoline, mix it with TCIII oil at a ratio of 8:1 and test it according to the technical manual. If the test fuel exceeds the zero Digatron threshold, the higher reading will become the maximum limit of the day. The source and grade of the gasoline must be announced when registration opens. At that time, testing equipment must be available to all competitors. This rule is not applicable at championship (Nationals, Divisionals, North American) races, straightaway or record races. Any driver using fuel which does not meet this rule will be disqualified. Additional fuel disqualification in the same day will result in the driver being automatically suspended for the remainder of the day. A driver may appeal a fuel disqualification by following the appeal procedure as covered by Rule 14. The driver must do this before leaving the inspection area, so a sample of the subject fuel can be collected and other tests performed with complete assurance that there has been no substitution or addition. All cost for transportation and such tests will be assessed against the appealing member. It is advisable to have unknown gasoline and oil checked before competition. Guidelines for fuel inspection procedure and equipment are in the current Stock Outboard inspection manual.

A. A 1.050" gas tank opening is required to accommodate the fuel meter.

- B. For the Junior Classes, the Digatron meter will be calibrated at a setting of -75 in Cyclohexane. In addition to other tests, the Germaine Reagent Test may be used for the JR, JH, AXR and AXH classes. If fuel tests positive for reaction according to the Germaine Reagent Test, the fuel is illegal and the driver must be disqualified.

RULE 17 • CLASSES AND MOTOR ELIGIBILITY

1. **MOTOR ELIGIBILITY.** The following are approved legal motors for use in the Junior Classes:
 - A. The Mercury 60-J
 - B. “The 13.2 CID OMC-A with an approved restrictor opening of a maximum diameter of **0.562 inches for JH and JR (there will be no further increases in restrictor opening size; however, the J Committee may reduce that size if required in order to maintain the Mercury motor in rule 17.1.C as the dominant engine)** and with approved restrictor at a maximum diameter set by the Junior Classes Committee for AXH and AXR.
 - C. The 15.9 cubic inch Mercury 15 (produced in 1999 or later) with approved restrictor for JH and JR and with no restrictor for AXH and AXR.
 - D. For the purpose of testing and evaluation the J committee may approve the racing of prototype restrictor plates in currently approved motors. Prototype restrictor plates may be used in motors raced at any non-championship event. An entry with a prototype restrictor plate used shall be counted as a legal entry for all purposes with the exception of awarding of national high points, championships, or records to the driver of the prototype motor. In such cases, a race in which a prototype restrictor plate is used shall be scored such that the place points are awarded as if the motor with the prototype restrictor plate entry did not exist. Granting prototype status in no way obligates the J committee to approve a specific restrictor plate for use in a motor for J racing. Petitions for prototype status shall be filed with the J chairman and shall be decided by the J committee. Prototype status shall be reviewed annually by the J committee. When a motor with a prototype restrictor plate is raced a copy of the scorer’s lap sheet shall be mailed to the J chairman.
2. **MOTOR RULES.** See inspection and technical data.
 - A. The engine shall retain the factory colors and decals, with the following exceptions:
 - 1) The powerhead may be either painted or unpainted. If it is painted, the color must be the same as the original color.
 - 2) Gearcases must be painted original factory colors or have no paint. Unpainted gearcases may be polished.
 - B. The engine shall be operated with the production upper and lower motor covers installed and supplied by the manufacturer. Air inlets into cowlings must remain closed as in original factory condition, either with plugs or with tape. Any year OEM motor cover may be used, i.e. Johnson or Evinrude for OMC motors, Mercury/Mariner covers for Mercury motors.
 - C. The mounting of a fuel tank to the engine or steering bar is prohibited.
 - D. Any type or make of spark plug is permissible.
 - E. Adjustable high speed carburetor jets are not permissible. Larger or smaller fixed jets are permissible.
 - F. The addition or removal of material from the flywheel is prohibited.
 - G. Polishing or removal of material on the carburetor or exhaust system is prohibited.
 - H. Broken parts may be repaired by welding or use of plastic compound, if all contour and dimensions remain as original. Broken skegs and cavitation plates may be used provided that the edges of the break or breaks have not been filed or smoothed or otherwise altered.
 - I. It is permissible to repair stripped threads by tapping oversize, or using helicoils, or using threaded inserts.
 - J. The addition of engine thrust brackets is permissible.
 - K. Any make or type of bolt, nut, screw, stud or washer may be used (with the exception of the butterfly screw), provided it does not require alteration of the engine to permit its use.
 - L. It is permissible to secure the impeller to the prop shaft by any means.
 - M. Internal machined surfaces may be re-machined so long as minimum and maximum dimensions are met. Cast or forged surfaces must remain as cast with no alterations, bead blasting, media blasting, or polishing. It is not permissible to re-machine surfaces that do not have specific dimensions. The reed plate openings are cast surfaces and must remain as cast.
 - 1) The Motor Inspector may compare questionable parts to known legal or new parts to determine legality.
 - N. Electric starters shall be permissible.
 - O. OMC**
 - 1) On the OMC A motors, safety wires must be in place from the steering bar-power head bolts. Drivers will be warned once before being disqualified. **A power head may be fitted with double threaded studs and attached to the drive housing and through the steering bar brackets and secured with washers and self locking nuts.**
 - 2) It is permissible to use non-OEM steering bars, steering bar brackets and throttle linkages. No modifications to the carburetor are permitted.
 - 3) Boyesen, Reeds part no. 122 shall be legal replacement parts.
 - 4) It shall be allowable to plug off the “water slot hole” with dimensions Z and Z11 in the engine specifications. It is also allowable to plug the small hole that is at the top of the water passage around the exhaust ports which has no dimensions in the engine specifications.
 - 5) The use of genuine OMC/BMC oversize pistons and rings is permissible. The use of aftermarket GLM manufactured pistons and rings in both standard and 0.030” sizes will be allowed. Part number for GLM standard piston kit is 24410, rings only 23710 and for 0.030” piston kit 24430 or rings only 23730.
 - 6) Port openings may have plastic compound added for repair.
 - 7) Only those OMC restrictor plates sold through APBA and marked “APBA” may be used in OMC motors competing in the Junior Classes.

ENGINE MODEL			JOHNSON	JKT
			EVINRUDE	EKT
VOLUME OF COMBUSTION CHAMBER AT T.D.C. TO TOP OF SPARK PLUG HOLE			MIN. CM ³	13.5
NUMBER OF CYLINDERS			2	
DISPLACEMENT (CUBIC INCH)			13.2	
CYLINDER BORE DIAMETER	STANDARD	G	2.188 +0.007 / -0.005	
	0.010 O.S.		2.198 +0.007 / -0.005	
	0.030 O.S.		2.218 +0.007 / -0.005	
CRANK STROKE		J	1.760 ±0.008	
ROD LENGTH		L	3.000 ±0.006	
PISTON DIMENSION		E	3.918 ±0.010	
		F	1.868 ±0.010	
		M	0.642 ±0.014	
PISTON RINGS	NUMBER PER PISTON		2	
	MATERIAL		CAST IRON	
	THICKNESS	UPPER	0.068 ±0.002	
		LOWER	0.062 ±0.002	
	DESIGN	UPPER	PRESSURE BACK	
		LOWER	RECTANGULAR	
	FREE DIAMETER	UPPER	2.235 ±0.025	
LOWER		2.335 +0.030 / -0.070		
NO. OF PORTS PER CYLINDER	TRANSFER		3 ROUND HOLES	
	EXHAUST		3 ROUND HOLES	
PORT HEIGHT	TRANSFER	A	3.480 MAX	
	TRANSFER	A3	3.490 MAX	
	EXHAUST	C	3.680 MAX	
PORT DIMENSION	TRANSFER	A1	0.625 ±0.010 DIA*	
	EXHAUST	C1	0.625 ±0.015 DIA*	
	TRANSFER	A2	0.625 ±0.025 DIA*	
	EXHAUST	C2	0.625 ±0.025 DIA*	
CYLINDER HEIGHT		K	4.880 ±0.015	
CYLINDER WIDTH		K1	4.520 ±0.025	
CRANKCASE HEIGHT		K2	1.830 ±0.020	
INTAKE MANIFOLD HEIGHT			1.040 ±0.025	
REED BLOCK (1 PER CYLINDER)	REED MATERIAL		STAINLESS STEEL OR PLASTIC	
	REED THICKNESS		0.011 ±0.0005	
	SHIM THICKNESS		0.012 ±0.001	
	REED STOP HEIGHT	H	0.256 ±0.020	
	REED STOP RADIUS	H1	5.000 ±0.500	
	CHECKING DISTANCE	Y	1.260 ±0.030	
	PORT LOCATION	N	1.430 ±0.015	
	PORT LENGTH	N1	1.010 ±0.030	
	PORT WIDTH (DIA.)	N2	0.675 ±0.025	
CYLINDER BASE		X	1.056 MIN.	
FLYWHEEL WEIGHT (LBS.) MIN.			5 LBS. 4 OZ.	
CARBURETOR	VENTURI DIAMETER		0.875 ±0.005	
	BORE DIAMETER		1.000 ±0.005	
MEG. LENGTH	U		10.633 ±0.050	
	U1		10.510 ±0.050	

POWERHEAD SPECIFICATIONS

MEG. RELIEF HOLE (DIA.)		T	0.280 ±0.060
INSIDE EXHAUST OUTLET HOLES		D	0.860 MIN. DIA.
		D1	0.480 MIN. DIA.
HOUSING RELIEF HOLE			0.310 ±0.020 DIA.
WATER RELIEF HOLE		P	0.040 ±0.010 DIA.
GEARCASE SPECIFICATIONS	IMPELLER BLADES	5	BEARING SPECIFICATIONS
	GEAR RATIO	14:19	
	Q	11.550 ±0.200	
	Q1	9.100 ±0.200	
	R	2.050 MIN.	
	S	0.980 MIN.	
	W	4.765 ±0.020	
	W1	4.340 ±0.100	
	V	18.000 ±0.060	
			ROLLER
			ROLLER
			BALL
			ROLLER W/RETAINER
			ROLLER
			ROLLER
			ROLLER/ROLLER THRUST
			ROLLER/ROLLER THRUST
			ROLLER/ROLLER

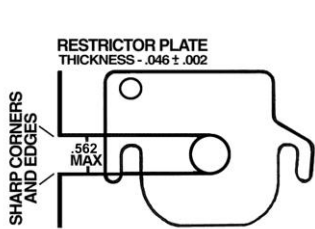

HOLE DIAMETER
 JH, JR 0.562"
 AXH, AXR 0.650"

NOTE: IT IS PERMISSIBLE TO ADD MATERIAL TO THE FOLLOWING WATER PASSAGES:

1. THE WATER SLOT HOLE (FORMERLY CONTROLLED BY DIMENSIONS Z AND Z1); AND
2. THE SMALL HOLE AT THE TOP OF THE WATER PASSAGES AROUND THE EXHAUST PORTS.

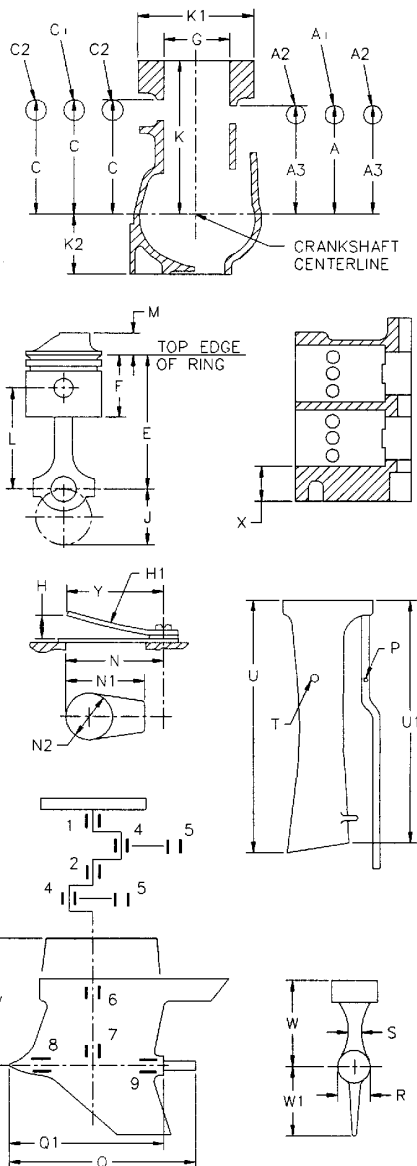

P. MERCURY

- 1) Steering bars, brackets and throttle linkage that have been approved by APBA shall be used.
- 2) The carburetor butterflies shall be replaced with the APBA full butterfly (APBA Part J55). It is also permissible to close the hole in the service carburetor butterfly with solder or epoxy.
- 3) It is permissible to replace the upper and lower rubber tower housing bushings. APBA Part J56.
- 4) It is permissible to place fuel cell material (foam) in the carburetor or utilize the APBA baffle.
- 5) It is permissible to remove the thermostat and to restrict the water in any manner within the thermostat housing. Water may be restricted at the 1/8" diameter tuner pipe cooling hole in the powerhead adapter plate.
- 6) It is permissible to remove the transom cleats located on the stern bracket.
- 7) The use of genuine Mercury oversized pistons is permissible. Any piston ring may be used in the Mercury motor provided that the piston is not altered in any way to accommodate the ring. The piston shall remain as furnished by the manufacturer.
- 8) It is permissible to remove the OEM fuel connector.
- 9) It is permissible to add a throttle stop to the carburetor.
- 10) It is permissible to use Mariner engines that meet all Mercury specifications.
- 11) It is permissible to use aftermarket or modified motor mounts. The driveshaft housing and brackets may not be modified to accept aftermarket or modified motor mounts.
- 12) It is permissible to use any bearing or seal. It is permissible to replace the OEM bearings with bearings of the same design and dimensions. It is not permissible to machine any surface to incorporate an aftermarket bearing or shim. The crankshaft and lower main (ball) bearing must be positively retained in their axial position in the cylinder block as originally manufactured, and the lower main (ball) bearing must be retained on the crankshaft by its original interference fit. Machining or other means, including wear, to allow the lower main (ball) bearing to move axially in relation to the cylinder block is strictly forbidden
- 13) It is permissible to hone connecting rods as long as all specifications are met.
- 14) It is permissible to hone the center main bearing shell as long as all specifications are met.
- 15) It is permissible to use any Bowden cable clamp when electric start is used.
- 16) It is permissible to use Mercury's "High Energy Ignition Kit" (Mercury part number: 339-7370A40).
- 17) It is permissible to remove foam from inside of the motor cowling.
- 18) It is permissible to replace the OEM fuel line with any fuel line.
- 19) It is permissible to replace the OEM tell-tale hose with any hose of equal or greater inside diameter. The OEM fitting at the block and the OEM tell-tale outlet nozzle must remain in place.
- 20) It is permissible to countersink the three (3) reed plate cover holes.

MERCURY 15 ENGINE SPECIFICATIONS			
(References are the same as the Mercury 25XS specifications)			
ITEM		REF.	SPEC.
Displacement	CID		15.9
No. of cylinders			2
Compr. Vol. @ TDC	min. cc		16.00
Transfer Ports	Timing	A	3.640+/-0.015
	Height	A1	0.630+/-0.010
	Width		0.950+/-0.020
Exhaust Ports	Timing	C	3.781+/-0.015
	Height	C1	0.630+/-0.010
Cylinder #1	Width		1x0.900; 1x0.950+/-0.020
Cylinder #2	Width		2x0.950+/-0.020"
Port Edge Radius			0.020 maximum
Exhaust Relief Hole		C	4.305 +/- 0.020
	Width/Height	C1	0.195 +/- 0.010
Comb. Ch. Corner Ht.		H	5.713+/-0.010
Cylinder Bore	(ref.)	G	2.376
	max.	G	2.41
Stroke		J	1.800+/-0.010
Piston	Material		Aluminum
	Deck Ht.	E	4.180+/-0.015
	Defl. Ht.	E1	0.563+/-0.005
	Total Ht.	F	2.653+/-0.030

Conn. Rod Length		L	3.100+/-0.005
Reed Block	no. of opens per cyl.		3
	length	M	0.906+/-0.015
	width	N	0.510+/-0.015
	stop ht.	P	0.325 MAX
	stop lt.	P1	1.23 MIN
	petal th.	O	0.008+/-0.002
Flywheel Weight	lbs/oz.		7.9 LBS. MIN.
CARBURETOR	VENTURI		1.00+/-0.01
	BOOST VENT		N/A
	THROAT		1.13+/-0.01
EXH. ADAPTER & PIPE		D	13.28+/-0.125
GEAR CASE SPECS — SAME AS OMC A SPECS (ALSO. SEE BELOW)			
DSHSG.		V	16.0+/- .25
G/C ADAPTER HEIGHT			0.50+/-0.01

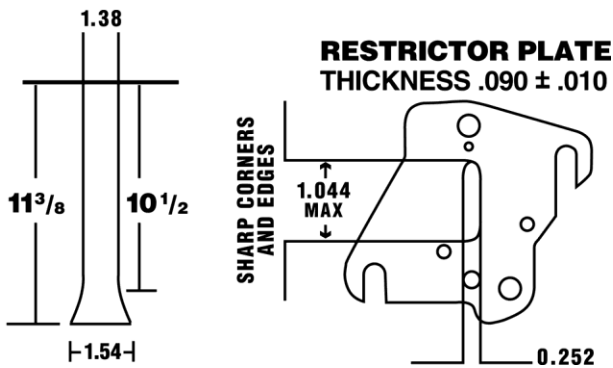

RULE 18 • HULLS See Glossary of Terms at the end of these rules

1. JUNIOR CLASSES HULLS

A. All Junior Class hulls shall meet the following dimensions:

	WIDTH "A"	LENGTH "B"	MIN. WEIGHT
JUNIOR HYDRO	-	-	300 LBS.
JUNIOR RUNABOUT	44"	9'5"	300 LBS.
AX HYDRO	-	-	325 LBS.
AX RUNABOUT	44"	9'5"	330 LBS.

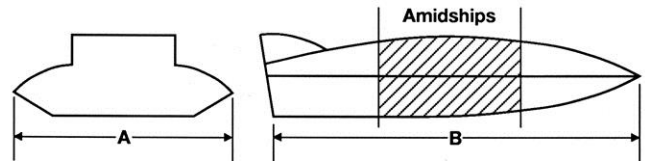

- "A" = Minimum beam measured at widest point across transom, but not to include spray rails or rub moldings.
- "B" = Minimum length measuring centerline of hull from trailing edge of bottom to a point perpendicular to stem and planing surface.
 - 1) The minimum overall weights shall include driver, hull, motor, steering bar, steering wheel, with cables and pulleys, motor controls, propeller, permanently attached speedometers and tachometer, permanently attached cushions and hardware, securely fastened weights, securely fastened fuel tank with remaining fuel, helmet, goggles and life jacket.
- B. A Runabout hull** is defined as a racing monoplane as qualified in this rule.
 - 1) The planing surface of a runabout shall be the lowest immersed surface at the aft end of the hull to a point 36 inches forward. Also, the planing surface shall be flat forward for 18 inches at the keel. For purpose of inspection, all measurements shall be made with a tolerance plus or minus 1/16 inch, as applicable.
 - 3) No part of the immersed surface may have a negative dead rise. The portside chine may have a maximum notch of 5/8" and turning fins may also be added to the immersed surface.
 - 4) Runabouts shall have no through the hull air passages, vented surfaces or wings. The intent of this rule is to have the air flow over the outside surfaces of the hull.
- C. Hydro motor height shall be measured relative to the lowest planing surface at the aft end of the boat. Afterplanes will not be included. The planing surface shall be flat (a tolerance of 1/16 inch for inspection purposes) transversely between the air traps and forward for 18 inches. Air traps shall be limited to a maximum depth of 5/8 inch at the aft end of the boat and 1-5/8 inch depth 18 inches forward. The maximum width of air traps is 7/8 inch each.

RULE 19 • JUNIOR CLASSES CHAMPIONSHIPS

Note: North American Championships require four starters, excluding step-ups, in at least one heat. All categories must comply with all NAC rules, in the Reference Book under **Special Events and Awards**.

1. There will be three levels of Championship events.
 - A. National Championship to be awarded at the national meeting by the Junior Class Committee. The National Championships must be run during the months of June, July, or August.
 - 1) The defending National Champion shall be qualified for the next year.
 - 2) Points shall be given for elimination races.
 - 3) The AXH, AXR, JH and JR drivers winning the APBA National Championship shall be awarded 1-US.
 - B. One Divisional Championship in each geographic division which shall be established according to the divisions for the Stock Outboard Category. The location of the Divisional Championship Race shall be decided by the Junior Class Committee. Divisional Championship shall be given to any APBA driver for points, trophies and prizes but only to drivers registered in their respective division for bonus points. The Divisional Champions shall not be seeded as a national qualifier at the National Championship event (it was felt that this rule would give the young people as much time and experience to compete at a National Championship event.)
 - C. North American Championship to be awarded at the national meeting by the Junior Class Committee. The North American Championships must be run during the months of June, July, or August.

RULE 20 • JUNIOR CLASSES AWARDS

1. Hall of Champions: The criteria for selection will be as follows:
 - a. A minimum of one driver selected to the Hall of Champions must be a participant in Junior Hydro or Junior Runabout and have qualified for the Hall of champions based solely on their accomplishments in JH and/or JR.
 - b. Additional drivers selected can only be inducted one time if no longer age eligible for Junior Hydro and/or Junior Runabout.
 - c. Drivers must have won either both hydro or runabout closed course National Championship in JH, JR, AXR or AXR. OR
 - d. Drivers must have one the overall High Point Championship (with no less than 10 legal races where he/she earned points) in JH, JR, AX or AXR.
 - e. The points shall be awarded as follows:
 - i. National Champion in JH, JR, AXH or AXR National Championship: 50 points each (must have been 8 legal starters)
 - ii. National High Point Champion: 40 points each (in JH, JR, AXH or AXR only)
 - iii. Break an existing straightaway or completion record: 20 points each.
 - iv. APBA JH, JR, AXH or AXR North American Championship: 25 points each
 - f. The second inductee, Junior or AX, must achieve a minimum of 60 points
- F. In case of a tie, the drivers who earned the greatest number of high points for the year shall be selected.
2. **Pop Trolian Award:** Goes to the Junior Runabout Class driver earning the most APBA points during the year.
3. **Don Allen Sr. Award:** Goes to the Junior Hydro Class driver earning the most APBA points during the year.
4. **Up and Coming Driver Award:** One award goes to a driver in the AX classes, to be chosen by the Junior Classes Committee. This award shall only be awarded to a given recipient one time.

JUNIOR CLASSES GLOSSARY OF TERMS

Aft: Toward the back of the boat. When you move toward the stern, you are going *aft*.

Aftermarket: Parts sold commercially to augment or modify an existing engine are *aftermarket* parts.

Afterplane: The boat's bottom surface, or section of the main hull, behind the sponsons.

Air Trap: A tunnel created by the inner vertical walls of the sponsons, which channels air forced underneath by the boat's forward motion.

Amidships: The center part of the boat.

Beam: The width of the hull. The right center side of the boat is the starboard beam; the left center side is the port beam.

Bona Fide Starter: Any boat that belongs in the class for which the heat is run, which enters the race course within the allotted time, and crosses the starting line no later than allowed by the rules.

Bow: The front, or forward part of the boat.

Buoy: One of several inflatable, anchored floating markers that indicate key spots on the course.

Entrance Buoy: The buoy marking a turn.

Cavitation Plate: A plate on the gearcase, parallel to the water, that reduces the potentially damaging force of water on the propeller.

Chine: The part of the boat below the waterline. A chine may be rounded or "soft"; or squared off—a "hard" chine.

Circular: The notice describing an upcoming sanctioned APBA race, sent to members.

Cockpit: The part of the boat where the driver sits or kneels.

Concavity: A surface that curves inward.

Cowling: The removable cover of an engine.

Dead rise: Lift from the centerline or keel to the chine (sometimes referred to as a V). An example of dead rise is the keel being 0 and the chine being 1" higher. Viewed from the front, the bottom of the boat would form a slight "V" shape. (*See diagram*)

Negative dead rise (the opposite of dead rise) is where the bottom of the boat arches (is concave). Negative dead rise is not permitted in any runabout—either fore to aft or port to starboard.

Fair Start: The instant when the bow of the first bona fide starter crosses the starting line no earlier than allowed by the rules.

Fin: A device to keep the boat stable in the turns.

Fore: Toward the front of the boat.

Full Field: The maximum allowed number of competitors racing.

Gearcase: The part of an engine that transfers force from the powerhead to the propeller.

Gunwale: The upper edge of the side of a boat.

Heat: A single continuous competitive event. (A race may consist of several *heats*, and multiple races may make up a *regatta*.)

Elimination Heat: Only the top placing competitors in an *elimination heat* are allowed to go on to race in the final.

High Points: Points tracked all season by category and class for each racer by APBA Headquarters, viewable on www.apba-racing.com.

Hull: A boat's internal framing, covered by an outer shell, usually made of plywood or fiberglass.

Hydroplane: A boat with more than one planing surface. It uses lift from air passing under the boat, usually touching only sponsons and propeller as it skims the surface of the water.

Immersed Surfaces: The wetted surface of the hull, including the bottom and chines, from transom to bow.

Jump the Gun: To cross the start line before the clock hits zero.

Keel: The "backbone" that runs along the center bottom of the boat.

Kneeldown: A style of open-cockpit raceboat without a seat, in which the driver kneels while driving.

Longitudinal, Longitudinally: Parallel to keel.

Milling: Boats running freely on the course during the few minutes before the start of a heat.

Monoplane: A boat with one planing surface, such as a runabout.

Picklefork: The forwardmost projection on each side of a boat. See *Sponson*.

Planing Surface: The lowest immersed surface from the aft end forward (excluding hydro airtraps) as defined by the hull categories.

Off Plane: A boat is *off plane* when it cannot run on top of the water. Usually the stern is lower than the bow, and much of the hull is immersed in the water, increasing resistance and slowing the boat.

On Plane: A boat is on plane when it achieves enough speed to run on top of the water (touching at only a few points) rather than plowing through it. Typically only a hydroplane's sponsons and propeller touch the water when it is on plane.

Port and Starboard: If you are in the boat looking forward, the **right** side of the boat is the *starboard* side; the **left** side is the *port* side.

Powerhead: The part of the engine where fuel is burned to generate power.

Race: An event or a series of heats that result in a single winner for each of the participating classes.

Records-

Competition Record: A speed record set during a race.

Straightaway Record: A record set by one boat on a surveyed course, usually making two consecutive passes by a buoy. (Also called a Kilo or 1/4 mile record)

Regatta: The complete set of races and time trials that take place pursuant to a single application for an APBA sanction.

Restrictor: A small plate, custom-made for each type of engine, with an aperture that limits fuel consumption.

Rocker: In a profile view (fore and aft), the rise from the keel to chine is "rocker".

Runabout: A monoplane, or boat with a single planing surface.

Sanction: APBA's written approval and documentation of a regatta.

Securely Fastened: Does not fall out when hull is turned upside down.

Shear Line: The fore and aft curvature from stem to transom of the deck as shown in side elevation.

Skeg: The lowest part of the gearcase, below the propeller.

Sponson: One of two projections on either side of a hydroplane's main hull; they are the main planing surfaces.

Start: A race starts when the first boat crosses the starting line in an event or series of events that results in a single winner for its class.

Clock Start: The field of drivers comes around the course so they cross the start/finish line just before the clock hits zero.

LeMans start: Drivers are lined up side by side on a dock or beach, and start the instant the signal is given.

Stem: The very forwardmost part of the bow.

Stern: The rear of a boat.

Transom: The back panel of the boat, vertical to the water, where the engine is mounted.

Transverse, Transversely: At right angles (90°) to keel.

Tunnel: A concavity greater than 1/16" within the planing surface.

Turn Boat, Turn Judge: In addition to officials on the judges' stand, turn judges in boats in the turns make calls and display flags.

